



HPX815E Gator™ Utility Vehicle



JOHN DEERE



OPERATOR'S MANUAL

HPX815E Gator™ Utility Vehicle

OMUC12667 ISSUE H7 (ENGLISH)

John Deere Horicon Works

Export Edition
Printed in U.S.A.



Introduction

Thank You for Purchasing a John Deere Product

We appreciate having you as a customer and wish you many years of safe and satisfied use of your machine.

MX00654.000020B-19-10MAY17

Using Your Operator's Manual

This manual is an important part of your machine and should remain with the machine when you sell it.

Reading your operator's manual will help you and others avoid personal injury or damage to the machine. Information given in this manual will provide the operator with the safest and most effective use of the machine. Knowing how to operate this machine safely and correctly will allow you to train others who may operate this machine.

If you have an attachment, use the safety and operating information in the attachment operator's manual, along with the machine operator's manual, to operate the attachment safely and correctly.

This manual and safety signs on your machine may also be available in other languages (see your authorized dealer to order).

Sections in your operator's manual are placed in a specific order to help you understand all the safety messages and learn the controls so you can operate this machine safely. You can also use this manual to answer any specific operating or servicing questions. A convenient index located at the end of this book will help you find needed information quickly.

The machine shown in this manual may differ slightly from your machine, but will be similar enough to help you understand our instructions.

RIGHT-HAND and LEFT-HAND sides are determined by facing in the direction that the machine will travel when going forward. When you see a broken line (-----), the item referred to is hidden from view.

Before delivering this machine, your dealer performed a predelivery inspection to ensure best performance.

MX00654.000020C-19-05JUN17

Machine Use

This machine is designed solely for use in customary utility operations, park and amenity area maintenance, for appropriate agricultural operations, and for winter work. Use in any other way is considered as contrary to the intended use.

This machine is not intended for use in forestry operations, unless equipped with a Falling Objects Protection Structure (FOPS) and/or Occupant Protective Structure (OPS). The operator station does not provide

adequate protection to the occupants in that environment unless equipped with a FOPS and/or OPS.

The cab available from the manufacturer is not designed to provide adequate protection from hazardous substances. The operator must wear appropriate personal protection equipment.

The manufacturer accepts no liability for damage or injury resulting from this misuse, and these risks must be borne solely by the user. Compliance with, and strict adherence to, the conditions of operation, service, and repair as specified by the manufacturer also constitute essential elements for the intended use.

This machine should be operated, serviced, and repaired only by persons familiar with all its particular characteristics and acquainted with the relevant safety rules (accident prevention). The accident prevention regulations, all other generally recognized regulations on safety and occupational medicine, and the road traffic regulations must be observed at all times.

Setting fuel delivery beyond published factory specifications or otherwise overpowering will result in loss of warranty protection for this machine.

Any arbitrary modifications carried out on this machine will relieve the manufacturer of all liability for any resulting damage or injury.

OUMX068.0000B78-19-05JUN17

Special Messages

Your manual contains special messages to bring attention to potential safety concerns and machine damage, as well as helpful operating and servicing information. Please read all the information carefully to avoid injury and machine damage.

⚠ CAUTION: Avoid injury! This symbol and text highlight potential hazards or death to the operator or bystanders that may occur if the hazards or procedures are ignored.

IMPORTANT: Avoid damage! This text is used to tell the operator of actions or conditions that might result in damage to the machine.

NOTE: General information is given throughout the manual that may help the operator in the operation or service of the machine.

MX00654.000020D-19-05JUN17

Attachments for Your Machine

There is a John Deere attachment or kit to make your new machine perform more tasks or be more versatile, whether your machine is a lawn tractor, compact utility tractor, or a utility vehicle.

Introduction

You can check out the entire line of attachments for your machine at JohnDeere.com or ask your John Deere dealer. From aerators to electric lift kits to tillers, there is a John Deere attachment or kit to fill every need.

OUMX068.000051C-19-05JUN17

Service Literature

If you would like a copy of the Parts Catalog or Technical Manual for this machine, visit The John Deere Technical Information Store at:

https://techpubs.deere.com/?cid=VURL_TechInfoStore

or call:

- **U.S. & Canada:** 1-800-522-7448.
- **All Other Regions:** Your John Deere dealer.

TH84124.0000199-19-05JUN17

Parts

We recommend John Deere quality parts and lubricants, available at your John Deere dealer.

When you order parts, your John Deere dealer needs the serial number or product identification number (PIN) for your machine or attachment. These are the numbers that you recorded in the Product Identification section of this manual.

Order Service Parts Online

Visit <http://JDParts.deere.com> for your Internet connection to parts ordering and information.

TC00531.00000E9-19-06MAR15

Contents

Product Identification	5
Safety Labels No-Text	6
Safety	11
Assembly	20
Machine Cleanout	25
Operating Controls	27
Operating	28
Optional Attachments & Kits	45
Service Intervals	49
Service Lubrication	50
Service Engine	51
Service Transmission	62
Service Steering & Brakes	66
Service Electrical	69
Service Miscellaneous	75
Troubleshooting	82
Storage	84
Specifications	86
John Deere Quality Statement	89
Service Records	91

Original Instructions. All information, illustrations and specifications in this manual are based on the latest information available at the time of publication. The right is reserved to make changes at any time without notice.

COPYRIGHT © 2017
DEERE & COMPANY
Moline, Illinois
All rights reserved

Product Identification

Record Identification Numbers

HPX815E

PIN (010001-)

If you need to contact an Authorized Service Center for information on servicing, always provide the product model and identification numbers.

You will need to locate the identification numbers for the product. Record the information in the spaces provided below.

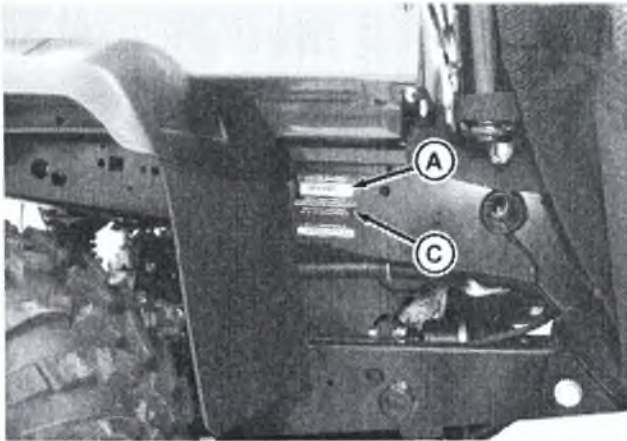

MXT014769—UN—19JUN15

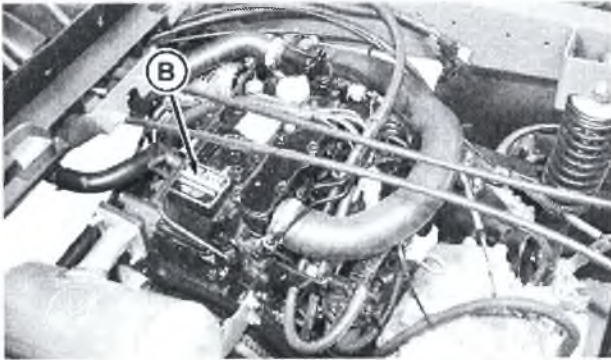

MXT008917—UN—11SEP13

DATE OF PURCHASE:

DEALER NAME:

DEALER PHONE:

PRODUCT IDENTIFICATION NUMBER (A):

ENGINE SERIAL NUMBER (B):

VEHICLE EMISSION CONTROL INFORMATION (C):

OUMX068,0001323-19-17JUL17

Safety Labels No-Text

Safety Label Location

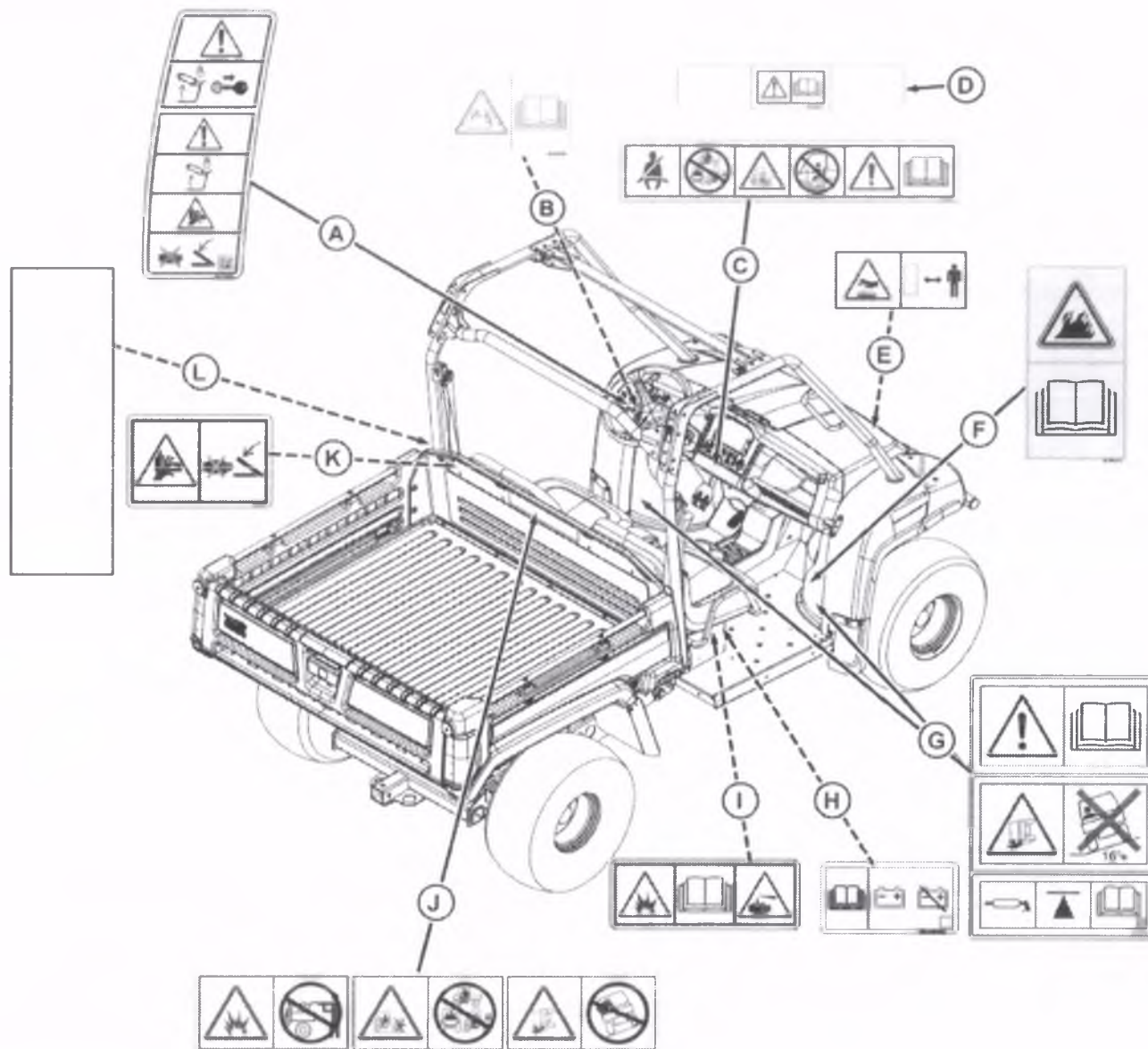

Cab and other components may be removed for better viewing

MXT020281—UN—14JUL17

- A—Help Prevent Injury when Dumping Loads - UC13078
- B—Avoid Injury From Equipment Fires - M160590
- C—Driver and Passenger Safety - M159667
- D—Avoid Injury - M160658 (On Optional Front Rack)
- E—Hot Surfaces - GX21121
- F—Avoid Injury From Equipment Fires - M165273
- G—Read Operator's Manual, Avoid Tipping - UC12756

- H—Read Operator's Manual, Service Battery - SU49461
- I—Avoid Injury From Battery Gases and Acids - M133159
- J—Avoid Injury From Explosion, Riders Can Fall Off and Be Killed, Rollover or Falling Off May Cause Death M161570
- K—Avoid Injury From Crushing - M120057
- L—Protective Structure Safety and Certification - UC14173

OUMX068.0001324-19-06AUG17

Safety Labels No-Text

Understanding the No-Text Machine Safety Labels



TCT005498—UN—11SEP12

At several important places on this machine, safety signs are affixed which signify potential danger. The hazard is identified by a pictorial in a warning triangle. An adjacent pictorial provides information on how to avoid personal injury. These safety signs, their placement on the machine, and a brief explanatory text are shown in this Safety section.

There can be additional safety information contained on parts and components sourced from suppliers that is not reproduced in this operator's manual.

MX00654,0000389-19-05JUN17

Help Prevent Injury When Dumping Loads

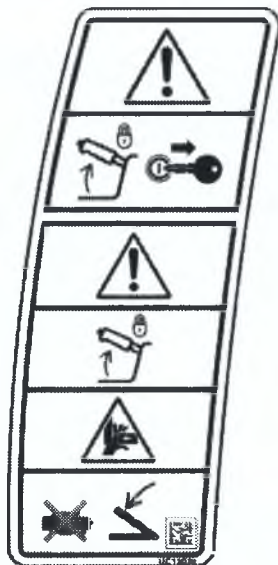

MXT020261—UN—05JUL17

BEFORE LEAVING VEHICLE:

- Stop engine
- Set park brake
- Remove key

HELP PREVENT INJURY WHEN DUMPING LOADS

- Lock park brake before dumping
- Operate dump on level ground only
- Keep hands away from cargo box

OUMX068,0001313-19-05JUL17

Avoid Injury From Equipment Fires

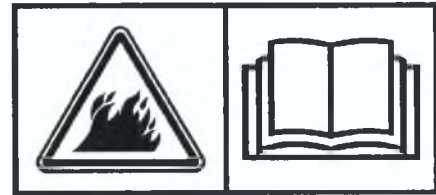

MXT018019—UN—04MAY16

- Avoid equipment fires.
- Accumulation of grass, leaves and debris on or near hot or moving parts can cause a fire.
- Inspect and clean the entire machine before, during and after use.
- Shut off engine and allow machine to cool before cleaning.
- Carefully read Operator's Manual Machine Clean out section for details.

MX00654,0000390-19-19JUN16

Driver and Passenger Safety



MXT008450—UN—27AUG13

Avoid Serious Injury or Death

- Driver must be at least 16 years old with a valid driver license.
- No more than one driver and one front passenger.
- Passenger must be able to grasp handholds with seat belt on and both feet on floor.

Young Drivers Increase Chance of Death

- Young drivers may not be able to control vehicle.
- No drivers younger than 16 years old.

MX10673,0000038-19-26JUL17

Read Operator's Manual



MXAL42776—UN—09APR13

Safety Labels No-Text

- This operator's manual contains important information necessary for safe machine operation.
- Carefully read operator's manual before operating machine or attachment. Observe all safety rules to avoid accidents.

MX00654.000038B-19-15JUN16

Avoid Injury



MXT007998—UN—29AUG13

Avoid Injury

To avoid injury, never carry riders. Use for cargo only, do not obstruct driver's view. Secure all loads. Max Capacity 100 lb. (45 kg).

OUC02005.0000164-19-19JAN15

Hot Surfaces

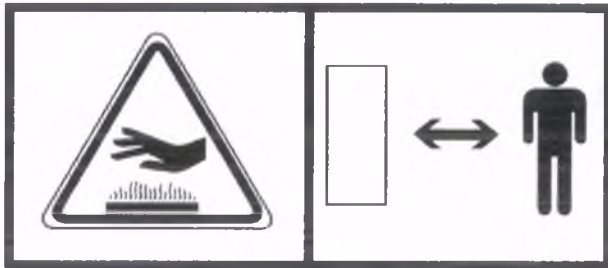

MXT008445—UN—27AUG13

Keep away from hot surfaces.

MX00654.00000D3-19-27AUG13

Avoid Injury from Tipping



MXT020262—UN—05JUL17

- Read operator's manual.
- Drive slowly when turning.
- Always use brakes going down a slope. Vehicle can takeoff (freewheel) downhill.
- No loads heavier than 1000 lb (454 kg). Spread load evenly. Tie loads down.
- Reduce speed and load, on rough or hilly ground.
- Maintain 14 psi (97 kPa) tire pressure front and rear.
- Do not exceed gross vehicle weight rating 3050 lb (1383 kg). Following loading instructions in operator's manual.
- Jacking Point.

MX10673.0000059-19-03AUG17

Read Operator's Manual, Service Battery

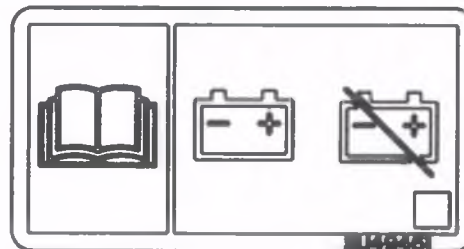

MXT020147—UN—16MAY17

- Read Operator's Manual
- Service Battery

OUMX068.0001296-19-16MAY17

Safety Labels No-Text

Avoid Injury From Battery Gases and Acid

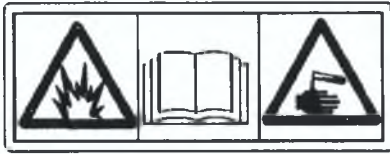

MXT007302—UN—23MAY13

- Shield eyes, explosive gases can cause blindness or injury.
- No sparks, flames, smoking.
- Sulfuric acid can cause blindness or severe burns.
- Keep out of the reach of children.
- Do not tip.
- Keep vent caps tight and level.
- Flush eyes immediately with water. Get medical help fast.

MX00654,0000394-19-21AUG14

- No riders in box or anywhere else.

MX00654,00000D6-19-22JUL14

Rollover or Falling Off May Cause Death

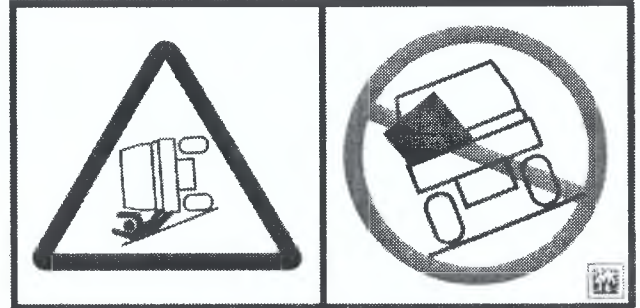

MXT008454—UN—20JUL17

- Read operator's manual.
- Drive very slowly when turning.
- Always use brakes going down a slope. Vehicle can takeoff (freewheel) downhill.
- Reduce speed and load on rough or hilly ground.

MX00654,00000D7-19-27AUG13

Avoid Injury From Explosion



MXT008452—UN—27AUG13

- Do not place gas container inside cargo box bed when filling.
- Place gas container on ground when filling.

MX00654,00000D5-19-27AUG13

Avoid Injury from Crushing

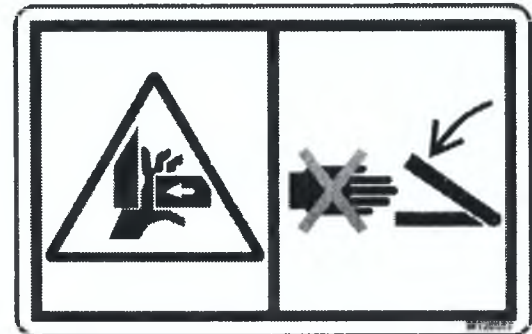

MXT020263—UN—05JUL17

- Avoid crushing injury.
- Keep hands away from cargo box.

OUMX068,0001315-19-05JUL17

Riders Can Fall Off and Be Killed



MXT008453—UN—20JUL17

- Maximum of one person to a seat.

Safety Labels No-Text

Protective Structure Safety and Certification Label

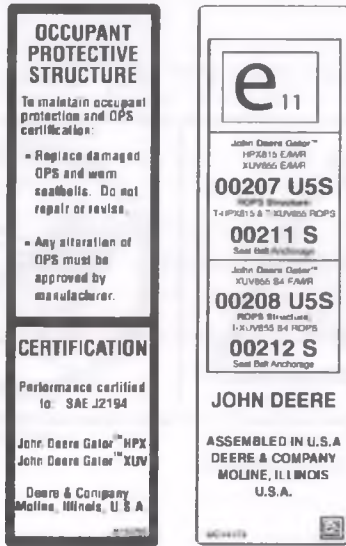

MXT020259—UN—30JUN17

One label is installed on your machine depending upon your region.

OCCUPANT PROTECTIVE STRUCTURE

To maintain occupant protection and OPS certification:

- Replace damaged OPS and worn seat belts. Do not repair or revise.
- Any alteration of OPS must be approved by manufacturer.

CERTIFICATION

Performance certified to: SAE J2194

John Deere Gator™ HPX

John Deere Gator™ XUV

Deere & Company Moline, Illinois, U.S.A.

OUMX068.0001310-19-30JUN17

Safety

Supervisor Safety Responsibilities

- Make sure all operators of this machine are thoroughly trained and are familiar with the operator's manual and understand the machine warning labels.
- Be sure to establish any special safety procedures for existing work conditions and train operators in those procedures.
- Supervisors, operators and mechanics should be familiar with and practice the safety standards that apply to this machine.

RH75544,0000159-19-08APR13

Operator Training Required

- Read the operator's manual and other training material. If the operator or mechanic cannot read English, it is the owner's responsibility to explain this material to them. This publication is available in other languages.
- Become familiar with the safe operation of the equipment, operator controls, and safety signs.
- All operators and mechanics should be trained. The owner of the machine is responsible for training the users.
- Never let children or untrained people operate or service the equipment. Local regulations may restrict the age of the operator.
- The owner/user can prevent and is responsible for accidents or injuries occurring to themselves, other people, or property.
- Operate the machine in an open, unobstructed area under the direction of an experienced operator when training.

RH75544,000015A-19-30APR13

Operating Safely

- Read, understand and follow all instructions in the operator's manual, on the machine and on the safety video before starting.
- The utility vehicle's tires are designed for off-road use only. Paved surfaces may seriously affect handling and control of the vehicle. If you must operate on a paved surface, travel slowly and do not make sudden turns or stops.
- Do not operate this vehicle on a frozen body of water. The vehicle could break through the ice, causing injury or even death.
- Go slowly and be extra careful when riding on snow-covered or ice-covered terrain.
- Slow down and be careful of traffic when operating near or crossing roadways. Use care when approaching blind corners, shrubs, trees, or other objects that may obscure vision.

- The operator should always make sure that the passenger is aware of correct safety procedures while riding in the utility vehicle.
- Use the correct flags, lights, signs and reflectors on the vehicle to warn other drivers when operating near roadways. Make sure these features are clean and visible for 500 feet (152 m).
- The passenger should always use the hand holds.
- To avoid serious injury, always ensure that occupants have safely secured their seat belts prior to starting this vehicle.
- Horseplay can lead to accidents, severe bodily injury or death. Do not attempt stunts, jumps, or quick acceleration to raise front wheels off the ground. These actions can result in accidents or vehicle overturns.
- Sit on the center of the seat and keep both feet within the foot platform perimeter. Clean foot platform if dirty, and remove any debris from around foot controls.
- Check for debris in engine compartment, especially around exhaust system components.
- Always use both hands for steering.
- Know location of controls and how and what they operate.
- Never operate utility vehicle while standing.
- Never operate utility vehicle with the cargo box raised.
- Check brake action before beginning vehicle operation. Adjust or service the brakes as necessary.
- To provide adequate braking ability and traction, do not tow any attachment or loaded trailer unless the cargo box is fully loaded.
- Before shifting into reverse, always check for obstacles or people behind the machine.
- Always back slowly.
- Inspect vehicle before operating. Be sure hardware is tight. Repair or replace damaged, badly worn, or missing parts. Be sure guards and shields are in good condition and fastened in place. Make any necessary adjustments before operating.
- Do not leave vehicle unattended when it is running.
- Operate during daylight or with good artificial light and if you drive at night, use the lights.
- Do not operate vehicle if under the influence of alcohol or other drugs.
- Avoid sudden starts, stops, or turns.
- Always use a level turn-around area.
- Do not wear radio or music headphones. Safe service and operation require your full attention.

JG81906,00006DC-19-01APR13

Safety

Using a Spark Arrestor

The engine in this machine is equipped with a spark arrestor muffler. The California Public Resources Code, section 4442.5 provides as follows:

No person shall sell, offer for sale, lease, or rent to any person any internal combustion engine subject to Section 4442 or 4443, and not subject to Section 13005 of the Health and Safety Code, unless the person provides a written notice to the purchaser or bailee, at the time of sale or at the time of entering into the lease or rental contract, stating that it is a violation of Section 4442 or 4443 to use or operate the engine on any forest-covered, brush-covered, or grass-covered land unless the engine is equipped with a spark arrestor, as defined in Section 4442, maintained in effective working order or the engine is constructed, equipped, and maintained for the prevention of fire pursuant to Section 4443. Cal. Pub. Res. Code 4442.5.

Other states or jurisdictions may have similar laws. A replacement spark arrestor for your machine is available from your authorized dealer. An installed spark arrestor must be maintained in good working order by the operator.

BB87125.0000D3A-19-19APR13

Parking Safely

1. Stop vehicle on a level surface, not on a slope.
2. Fully lower the cargo box and any attachments on the machine that can be lowered.
3. Lock park brake.
4. Stop engine.
5. Remove key.
6. Before you leave the operator's seat, wait for engine and all moving parts to stop.
7. Disconnect the negative battery cable or remove the spark plug wires (for gasoline engines) before servicing the machine.

OUMX068 00005F5-19-11JUL13

Protect Children/Small Adults and Prevent Accidents

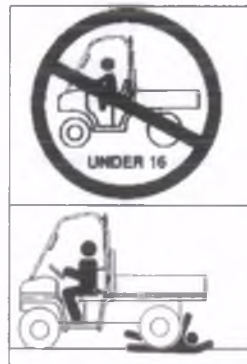

MXAL43278—UN—15MAR13

- This utility vehicle should not be operated by anyone under the age of 16 years.
- This utility vehicle should not be operated by anyone without a valid driver license.
- Young drivers may not be physically able to control the machine or may not be mature enough to make safe driving decisions.
- Do not allow children to ride as a passenger in this vehicle. Children may not be able to sit safely in the passenger seat and use handholds properly. Passengers must be able to grasp handholds with their back against the seat, seat belt on, and both feet on the floor.
- Passenger should always use the handholds while the vehicle is moving.
- Seat belts installed on utility vehicles are not designed to restrain children.
- Never carry passengers, especially children, in the cargo box area. Do not tow children in a cart or trailer.
- Never assume that children remain where you last saw them. Stay alert to the presence of children.
- Before backing or turning, look behind and around the utility vehicle for children.
- Be alert at all times, drive forward and in reverse carefully. People, especially children, can move quickly into an area of operation.
- Use extra care when coming to blind corners, shrubs, trees, or other objects that may block vision.
- Misuse and recreational riding can lead to accidents, severe bodily injury, or death.

OUO2005.0000169-19-28FEB17

Avoid Excessive Speeds



MXAL43279—UN—15MAR13

- Always wear an approved helmet when operating the

Safety

vehicle in an aggressive manner, on rough or uneven terrain, or at higher speeds.

- Always travel at a speed that is safe and proper for the terrain, visibility and operating conditions, and your experience operating the machine.
- Use caution when operating the machine in reverse. Use a slow speed and do not make sharp turns. Always look behind before backing.
- Never travel at excessive speeds on slopes, either going up or down. Use a slow speed and do not make sharp turns. Become experienced driving the machine on small slopes before driving on larger hills.

MX10673,0000023-19-19JUL17

Avoid Tipping



MXAL43279—UN—15MAR13

Accidents resulting in serious injury or death can occur from tipping the utility vehicle. Observe the following practices to help prevent accidents and always wear an approved helmet when operating the vehicle in an aggressive manner, on rough or uneven terrain, or at higher speeds.

- Drive very slowly when turning. Sharp turns could cause the utility vehicle to tip over.
- Reduce speed and exercise extreme caution on slopes or on rough ground.
- Do not overload vehicle and avoid shifting loads. Reduce load when operating over rough or hilly terrain.
- Do not stop or start suddenly when going uphill or downhill. Be especially cautious when changing direction on slopes.
- Stay alert for holes, rocks, and other hidden hazards in the terrain.
- Keep away from drop-offs, ditches, embankments, as well as ponds and other bodies of water. The machine could suddenly roll over if a wheel goes over the edge of a cliff or ditch or if the edge caves in.
- Keep front wheels straight at crest of hill or going over bumps.
- When descending a hill, remove foot from accelerator pedal and apply brakes to reduce speed and maintain control.
- Do not make unauthorized changes or modifications to the utility vehicle.
- This list of potential overturning hazards is not exhaustive.

MX10673,0000022-19-19JUL17

Use Seat Belts, Nets and Doors Properly



MXT008507—UN—10JAN17

- Use a seat belt and doors or nets, if equipped, to minimize chance of injury from an accident, such as an overturn.
- Do not operate machine with any portion of the operator safety system inoperative or removed.
- Inspect seat belts, nets and doors for proper operation before each machine use.
- Insert metal tab of net, if equipped, into buckle until it clicks, indicating it is latched. Pull back on net to confirm it is securely latched.
- Layers of heavy clothing can interfere with proper positioning of the seat belt and can reduce the effectiveness of the seat belt.
- Never modify, disassemble, or attempt to repair a seat belt, nets or doors.
- Inspect seat belts, nets and doors, if equipped, at least once a year. Look for signs of loose hardware or material damage, such as cuts, fraying, extreme or unusual wear, or abrasion. Replace only with John Deere approved replacement parts.
- Replace entire seat belt if mounting hardware, buckle, belt, or retractor show signs of damage.

OUMX068,00002E3-19-28FEB17

Vibration

All operator's seats approved by John Deere are approved in accordance with 78/764/EEC or EU 1322/2014 Annex XIV, being allocated an average of the vibration acceleration actually measured at the seat (a_{ws}) equivalent to $\leq 1.25 \text{ m/s}^2$.

Measures to reduce vibration may include:

- Appropriate style of driving, e.g. not too fast
- Correctly adjusted suspension-front and rear
- Correct tire pressure

MX10673,0000044-19-28JUL17

Sound Level

Operator Ear: The driver perceived noise level has been measured in accordance with (EU) 1322/2014 Annex XIII using test method 1 or 2. When measured using test method 1, maximum noise levels were $\leq 90 \text{ dB(A)}$.

Safety

When measured using test method 2, maximum noise levels were ≤ 86 dB(A).

External Sound Emission (Drive-by noise): The external sound emission levels have been measured in accordance with (EU) 2016/96 Annex III. Maximum sound levels were ≤ 85 dB(A).

MX10673.0000045-19-28JUL17

Keep Occupant Protective System (OPS) Installed Properly

- Never operate the machine without the OPS installed.
- Make certain all parts of the OPS are installed correctly if the OPS structure is loosened or removed for any reason. All OPS hardware should be tightened to the proper torque per manufacturer's recommendations.
- Any alteration of the OPS must be approved by the manufacturer. The protection provided by the OPS will be impaired if the OPS is subjected to structural damage, is involved in an overturn incident, or is in any way altered by welding, bending, drilling, or cutting.
- Never attempt to repair a damaged or altered OPS. It must be replaced to maintain the manufacturer's certification of the structure.

BB87125.0000D40-19-19APR13

Keep Riders Off Vehicle



MXT008506—UN—10JAN17

- Seating is provided for operator and one adult passenger.
- Never allow riders in the cargo box or other areas where seats are not provided.
- Riders on vehicle are subject to injury such as being struck by foreign objects or being thrown off of the vehicle and severely injured or killed.
- Riders affect the operator's ability to control the vehicle as well as its center of gravity. Also, riders could obstruct the operator's view resulting in the vehicle being operated in an unsafe manner.

MX00654.00000B7-19-28FEB17

Before Driving

1. Clean foot platform if dirty, and remove any debris from around foot controls. Sit on the center of seat and keep both feet inside foot platform perimeter.
2. Inspect utility vehicle for signs of wear or damage.
3. All safety equipment must be in good condition and fastened in place:
 - Lights.
 - Shields.
 - Safety start devices.
4. Before moving, check around utility vehicle, be sure no one is near it.
5. Inspect mechanical condition of your vehicle before each use to minimize chance of injury or being stranded. Remember, you can ride farther in an hour than you can walk in a day.

Be sure to check condition of tires and wheels, wheel hardware torque, and maintain proper tire pressure.

6. Securely anchor all loads.

SP66632.0004714-19-19APR13

Transport Loads Safely

- Be sure load is evenly distributed in cargo box.
- Do not load above load guard.
- Securely anchor all loads in cargo box.
- Reduce cargo box load when operating on rough or hilly terrain.

SP66632.0004712-19-19APR13

Using Front Attachments

Remove front attachments such as drawbar hitches, hitch mounted winches, or blades when operating on rough or uneven terrain. Front attachments may contact the ground when operating on rough or uneven terrain which may cause loss of control or rollover.

OUMX068.0000634-19-22SEP16

Towing Loads Safely With Utility Vehicle

- To provide adequate braking ability and traction, weight of towed load (trailer plus cargo) must never exceed the vehicle payload (operator plus passenger plus cargo box load).
- Do not tow a load that exceeds the maximum allowable towing load for this vehicle, as specified in this operator's manual.
- Stopping distance increases with speed and weight

Safety

of towed load. Travel slowly and allow extra time and distance to stop.

- Tow load at a speed slow enough to maintain control.
- Excessive towed load can cause loss of traction and loss of control on slopes. Reduce towed weight when operating on slopes.
- Never allow children or others in or on towed equipment.
- Use only approved hitches. Tow only with a machine that has a hitch designed for towing. Do not attach towed equipment except at the approved hitch point.
- Follow the manufacturer's recommendations for weight limits for towed equipment and towing on slopes.
- If you cannot back up a slope with a towed load, the slope is too steep to operate on with the towed load. Reduce the towed load or do not operate.
- Do not turn sharply. Use additional caution when turning or operating under adverse surface conditions. Use care when reversing.
- Do not shift to neutral and coast downhill.

BB87125.0000D45-19-19APR13

Driving On Rough Terrain



MXAL43282—UN—15MAR13

- Always wear an approved helmet when operating the vehicle in an aggressive manner, on rough or uneven terrain, or at higher speeds.
- Use existing trails. Avoid terrain such as dangerous slopes and impassable swamps. Watch carefully for bumps, holes, ruts, loose terrain, or other obstacles.
- Look ahead at terrain. Know what is coming and be prepared to react. Be alert for hazards.
- Keep front wheels straight at crest of hill or going over bumps.
- Reduce speed according to trail, terrain, and visibility conditions.
- The passenger should always use the hand holds.

MX10673.0000024-19-19JUL17

Climbing or Descending a Hill or Slope



MXT008509—UN—10JAN17

- Always use the brakes when going down slopes. The utility vehicle can speed up (freewheel) going down a slope. Engine or clutch braking effect is minimal.
- Balance loads evenly and secure them. Braking could shift the load and affect vehicle stability.
- Sit on center of seat and keep both feet within foot platform.
- Never drive past the limit of visibility. Slow down near crest of hill until getting a clear view of the other side. Never go over the top of any hill at a high speed. An obstacle, sharp drop, another vehicle or person, could be on the other side of the hill.
- Keep front wheels straight at crest of hill or going over bumps.
- Do not stop or start suddenly when going uphill or downhill. Be especially cautious when changing direction on slopes.
- If vehicle stops or loses power going up a hill, lock park brake to hold vehicle on slope. Maintain direction of travel and release brake slowly. Back straight down hill slowly while maintaining control. Do not turn vehicle sideways. Vehicle is more stable in a straight forward or rearward position.
- Always descend hill or slope at slow speeds and in a controlled manner. When descending a hill, remove foot from accelerator pedal and apply brakes to reduce speed and maintain control.
- The vehicle has a limited amount of engine braking that can assist when going down a hill or slope, but it is highly recommended to remove foot from throttle pedal and to use service brakes during descent as well.
- If the vehicle is freewheeling (engine braking is not engaged), use the service brakes to slow vehicle travel. Do not reengage engine braking (do not depress the throttle pedal) when freewheeling as that may cause the vehicle to skid.

RH75544.0000169-19-28FEB17

Safety

Driving Across Slopes



MXT008509—UN—10JAN17

- Reduce speed and use caution on slopes and in sharp turns.
- Stay alert for holes, rocks and other hidden hazards in the terrain.
- When riding on soft terrain, turn front wheels slightly uphill to keep utility vehicle on a straight line across the hill.
- If utility vehicle begins to tip, turn front wheel downhill to gain control before proceeding.

BB87125.0000D48-19-28FEB17

torque using the proper procedure anytime it is loosened.

RH75544.000016C-19-08APR13

Wear Appropriate Clothing



MXAL41935—UN—18FEB13

- Always wear an approved helmet when operating the vehicle in an aggressive manner, on rough or uneven terrain, or at higher speeds.
- Helmets should fit properly and be approved for motorcycle use on standard roadways by the appropriate governing organizations for the region in which the vehicle is being used.
- Wear close fitting clothing and safety equipment appropriate for the job.
- Certain operating conditions may dictate that the operator and any passenger wear appropriate safety equipment while operating the vehicle. Be prepared for any existing and potential conditions before operating machine.
- Local safety or insurance regulations may require additional safety equipment, such as eye protection or a hard hat.
- Always wear substantial footwear and long trousers. Do not operate the equipment when barefoot or wearing open sandals.

MX00654.00000BD-19-05JUL17

Riding Through Water

- Avoid water whenever possible. If drive belt becomes wet, slippage will occur and vehicle will lose power.
- Never cross any body of water where depth may be unknown to the operator. As an operational guideline, deep water is considered anything in excess of 152 mm (6 in) in depth. Tires may float, making it difficult to maintain control.
- Choose a course within the waterway where both banks have a gradual incline. Cross at a point known to be safe.
- Proceed at a slow, steady speed to avoid submerged obstacles and slippery rocks.
- Avoid water crossings where the operation of a utility vehicle may cause damage to waterway beds or erode waterway shoreline.
- Never operate this vehicle in fast-moving water.
- Stopping ability of vehicles with external disk brakes may be affected after driving through water. If necessary, apply brakes several times to dry them out.

SP66632.0004718-19-05JUL17

Practice Safe Maintenance



MXAL41933—UN—18FEB13

- Only qualified, trained adults should service this machine.
- Understand service procedure before doing work. Keep area clean and dry.
- Never lubricate, service, or adjust machine while it is moving. Keep safety devices in place and in working condition.
- Keep hands, feet, clothing, jewelry, and long hair away from any moving parts, to prevent them from getting caught.
- Disconnect battery(ies) or remove spark plug wires (for gasoline engines) before making any repairs.

Checking Wheel Hardware

- A serious accident could occur causing serious injury if wheel hardware is not tight.
- Check wheel hardware tightness often during the first 100 hours of operation.
- Wheel hardware must be tightened to specified

Safety

- Keep all nuts and bolts tightened.
- Securely support any machine elements that must be raised for service work. Lock service latches before working on machine with raised attachments.
- Never run engine unless park brake is locked.
- Keep all parts in good condition and properly installed. Fix damage immediately. Replace worn or broken parts. Replace all worn or damaged safety and instruction decals.
- To prevent fires, remove any buildup of grease, oil, or debris from the machine, especially the engine.
- Do not modify machine or safety devices. Unauthorized modifications may impair its function and safety.
- Do not wear radio or music headphones while servicing the machine. Safe service requires your full attention.
- Disconnect battery ground cable(s) (-) on the machine or remove attachment from machine before welding on the machine.

RH75544,000016E-19-08APR13

Prevent Fires

- Please review these recommendations with all operators. See your John Deere dealer with questions.
- Always follow all safety procedures posted on the machine and in this operator's manual. Before carrying out any inspection or cleaning, always shut off engine, set parking brake, and remove ignition key.
- Besides routine maintenance, one of the best ways to keep your John Deere equipment running efficiently and to reduce fire risk is to regularly remove debris buildup from the machine.
- After operating, allow machine to cool in an open area before cleaning or storing. Do not park machine near flammable materials, such as wood, cloth, or chemicals, or near an open flame or other sources of ignition, such as a water heater or furnace.
- Completely remove any combustible materials from equipment before storing by emptying any grass catcher bags, containers, and cargo boxes.
- Debris can accumulate anywhere on the machine, especially on horizontal surfaces. Remove grass and debris completely from engine compartment, muffler area, and from the mower deck or cutting units both before and after operating machine. Additional cleaning may be necessary when mowing or mulching in dry conditions.
- In addition to cleaning machine before using and storing, keeping engine area clean provides the greatest impact on fire prevention. Other areas requiring regular inspection and cleaning include behind wheel rims, wire harness, hose or line routing, mowing attachments, etc. Compressed air, leaf

blowers, or high pressured water assists in keeping these areas clean.

- Frequency of these inspections and cleaning will vary depending on a number of factors, including operating conditions, machine configuration, operating speeds, and weather conditions, (particularly dry, hot, and windy conditions). When you are operating in these conditions, inspect and clean these areas frequently throughout the day.
- Excess lubrication or fuel/oil leaks or spills on the machine can also serve as collection sites for debris. Prompt machine repair and oil and fuel clean-up reduces the potential for debris collection.
- Bearing failures or overheating can result in a fire. To reduce this risk, always follow the instructions in the machine operator's manual regarding lubrication intervals and locations. Contact your local dealer if you have any questions about the lubrication intervals or location and if any unusual noises are coming from areas where bearings might be located. Washing the machine while warm may also reduce bearing life and increase potential for premature bearing failure.
- Always shut off fuel when storing or transporting machine, if the machine has a fuel shutoff.
- Check fuel lines, tank, cap, and fittings frequently for cracks or leaks. Replace if necessary.

OU02005,0000221-19-05JUL17

Do Not Modify Machine

Do not make any unauthorized modifications to the machine in any way.

Modifications can result in making the machine unstable, increasing the possibility of rollover causing severe bodily injury or death.

RH75544,0000170-19-08APR13

Tire Safety



MXAL41937—UN—18FEB13

Explosive separation of a tire and rim parts can cause serious injury or death:

- Do not attempt to mount a tire without the proper equipment and experience to perform the job.
- Always maintain the correct tire pressure. Do not inflate the tires above the recommended pressure. Never weld or heat a wheel and tire assembly. The heat can cause an increase in air pressure resulting in a tire explosion. Welding can structurally weaken or deform the wheel.

Safety

- When inflating tires, use a clip-on chuck and extension hose long enough to allow you to stand to one side and NOT in front of or over the tire assembly.
- Check tires for low pressure, cuts, bubbles, damaged rims or missing lug bolts and nuts.

RH75544.0000171-19-08APR13

Handling Fuel Safely



MXAL41938—UN—18FEB13

To avoid personal injury or property damage, use extreme care in handling fuel. Fuel is extremely flammable and fuel vapors are explosive:

- Extinguish all cigarettes, cigars, pipes, and other sources of ignition.
- Use only an approved fuel container. Use only non-metal, portable fuel containers approved by the Underwriter's Laboratory (U.L.) or the American Society for Testing & Materials (ASTM). If using a funnel, make sure it is plastic and has no screen or filter.
- Never remove the fuel tank cap or add fuel with the engine running. Allow engine to cool before refueling.
- Never add fuel to or drain fuel from the machine indoors. Move machine outdoors and provide adequate ventilation.
- Clean up spilled fuel immediately. If fuel is spilled on clothing, change clothing immediately. If fuel is spilled near machine, do not attempt to start the engine but move the machine away from the area of spillage. Avoid creating any source of ignition until fuel vapors have dissipated.
- Never store the machine or fuel container where there is an open flame, spark, or pilot light such as on a water heater or other appliance.
- Prevent fire and explosion caused by static electric discharge. Static electric discharge can ignite fuel vapors in an ungrounded fuel container.
- Never fill containers inside a vehicle or on a truck or trailer bed with a plastic liner. Always place containers on the ground away from your vehicle before fueling.
- Remove fuel-powered equipment from the truck or

trailer and refuel it on the ground. If this is not possible, then refuel such equipment with a portable container, rather than from a fuel dispenser nozzle.

- Keep the nozzle in contact with the rim of the fuel tank or container opening at all times until the fueling is complete. Do not use a nozzle lock-open device.
- Never overfill fuel tank. Replace fuel tank cap and tighten securely.
- Replace all fuel container caps securely after use.
- For gasoline engines, do not use gas with methanol. Methanol is harmful to your health and to the environment.

RH75544.0000172-19-16APR13

Handling Waste Product and Chemicals

Waste products, such as, used oil, fuel, coolant, brake fluid, and batteries, can harm the environment and people:

- Do not use beverage containers for waste fluids - someone may drink from them.
- See your local Recycling Center or authorized dealer to learn how to recycle or get rid of waste products.
- A Material Safety Data Sheet (MSDS) provides specific details on chemical products: physical and health hazards, safety procedures, and emergency response techniques. The seller of the chemical products used with your machine is responsible for providing the MSDS for that product.

RH75544.0000173-19-08APR13

Use Electronic Display Properly

Electronic displays are secondary devices intended to aid the operator in performing field operations, increase comfort and provide entertainment. Displays offer a wide range of functionality, are used in many different machine system applications and can be used with other secondary devices such as handheld electronic devices.

A secondary device is any device that is not required to operate your machine for its primary use. The operator is always responsible for safe operation and control of the machine.

To prevent injury while operating the machine:

- Position the display according to the installation instructions. Ensure that the device is secured and does not obstruct the driver's view or interfere with the machine operating controls.
- Do not become distracted by the display. Stay alert. Pay attention to the machine and surrounding environment.
- Do not change settings or access any functions that require prolonged use of the display controls while machine is moving. Stop the machine in a safe

Safety

location and place in park position before attempting such operations.

- Never set the volume so high that you cannot hear outside traffic and emergency vehicles.

To promote safe operation, certain functions of displays may be disabled unless the machine movement is restricted and/or has been placed in the park position. Overriding this safety feature may violate applicable law and can result in damage, serious injury, or death.

Only use available display functionality when conditions permit you to do so safely and in accordance with instructions provided. Always observe safe driving rules, state, or local laws and traffic regulations when using any secondary device.

DX,ELEC.DISPLAY-19-13JAN15

Assembly

Parking Safely

1. Stop vehicle on a level surface, not on a slope.
2. Fully lower the cargo box and any attachments on the machine that can be lowered.
3. Lock park brake.
4. Stop engine.
5. Remove key.
6. Before you leave the operator's seat, wait for engine and all moving parts to stop.
7. Disconnect the negative battery cable or remove the spark plug wires (for gasoline engines) before servicing the machine.

OUMX068.000056C-19-25JUN13

Install Wheels

CAUTION: Avoid injury! The machine can fall or slip from an unsafe lifting device or supports.

- Use a safe lifting device rated for the load to be lifted.
- Lower machine onto jack stands or other stable supports and block wheels before servicing.

1. Install plastic cap on each rear axle hub.
2. Raise vehicle with a safe lifting device. Place support stands under vehicle.

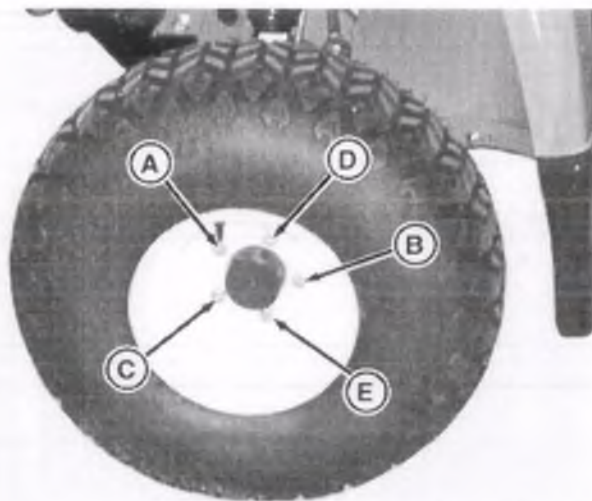

MXT009131—UN—27SEP13

3. Attach each wheel to axle hub with valve stem to outside using five wheel bolts. Tighten wheel bolts evenly in proper sequence (A), (B), (C), (D), and (E) until snug. Finish tightening to 81 N·m (60 lb.-ft.) using a torque wrench.
4. Remove support stands and lower vehicle.

OUO2005.0000209-19-27SEP13

Check Tire Pressure

CAUTION: Avoid injury! Explosive separation of tire and rim parts is possible when they are serviced incorrectly:

- Do not attempt to mount a tire without the proper equipment and experience to perform the job.
- Do not inflate the tires above the recommended pressure.
- Do not weld or heat a wheel and tire assembly. Heat can cause an increase in air pressure resulting in an explosion. Welding can structurally weaken or deform the wheel.
- Do not stand in front or over the tire assembly when inflating. Use a clip-on chuck and extension hose long enough to allow you to stand to one side.

1. Check tires for damage.

NOTE: Refer to the SPECIFICATIONS section for tire pressures.

2. Check tire pressure with an accurate lower pressure gauge.
3. Add or remove air, if necessary.

OUO2005.000020A-19-27SEP13

Install Steering Wheel

1. Remove and discard plastic protective cap from steering shaft.
2. Install steering wheel onto steering shaft. Turn steering wheel to position front wheels straight and facing forward.
3. Remove steering wheel.
4. Apply multi-purpose grease to steering shaft.

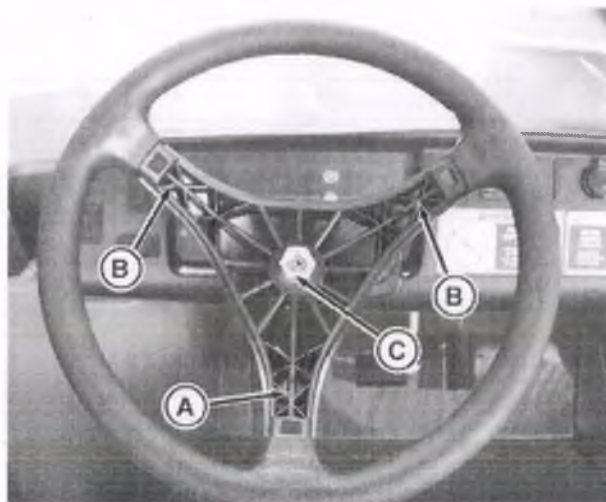

MXT009132—UN—27SEP13

Assembly

5. Install steering wheel onto steering shaft with one spindle (A) positioned at 180° at bottom of wheel and spindles (B) at approximately 45° at top of wheel, as shown.
6. Install nut (C) and tighten to 38 N•m (28 lb-ft).

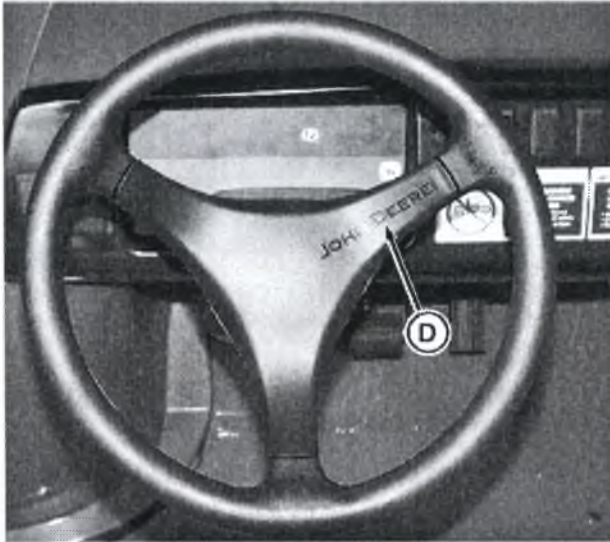

MXT009133—UN—27SEP13

7. Install cover (D) so the John Deere name is positioned properly.

OUC02005.000020B-19-27SEP13

Check Battery Voltage

! CAUTION: Avoid injury! The battery produces a flammable and explosive gas. The battery may explode:

- Do not smoke or have open flame near battery.
- Wear eye protection and gloves.
- Do not jump start or charge a frozen battery. Warm battery to 16°C (60°F).
- Do not connect the negative (-) booster cable to the negative (-) terminal of the discharged battery. Connect at a good ground location away from the discharged battery.

Remove and discard the protective caps from the positive (+) and negative (-) terminals.

Battery is filled with acid and charged when it left the factory. To extend battery life, check voltage prior to delivery. Fully charge the battery if voltage is less than 12.6 volts.

OUC02005.000020B-19-27SEP13

Connect Battery

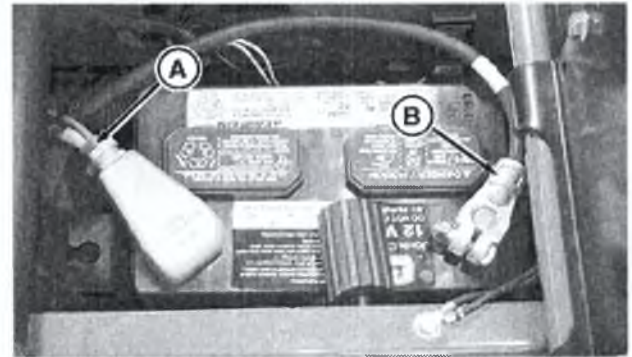

MXT009134—UN—27SEP13

1. Install red positive battery cable (A) to positive (+) terminal first using M6x16 capscrew, flat washer, and nut. Tighten the connection.
2. Install black negative battery cable (B) to negative (-) terminal last using M6x16 capscrew, flat washer, and nut. Tighten the connection.
3. Apply petroleum jelly on battery terminals to help prevent corrosion.
4. Slide protective cover down the battery positive cable and seat it over the positive (+) terminal.

OUC02005.0000210-19-27SEP13

Install Cargo Box with Power Lift Kit

A cargo box power lift kit is available as an option. When installing the Power Lift for Cargo Bed Kit, see the separate installation instructions included in the kit.

MX10673.0000066-19-07AUG17

Install Cargo Box with Prop Rod

! CAUTION: Avoid injury! Machine component or attachment is heavy. Use a safe lifting device or get an assistant to help lift, install, or remove component or attachment.

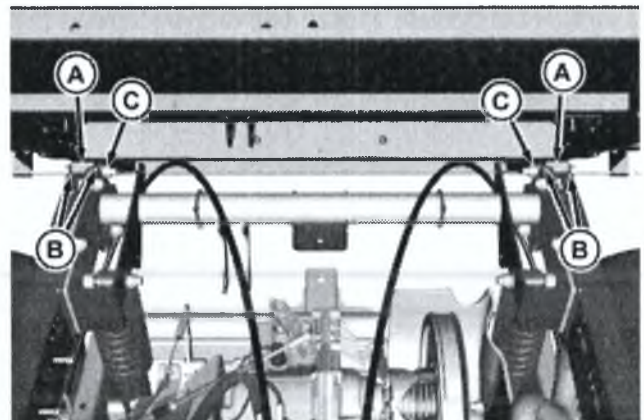

MXT020712—UN—08AUG17

Assembly

1. Position cargo box onto the machine frame so hinges (A) are positioned inside pivot brackets (B).
2. Install cargo box using M12x75 bolts and flange lock nuts (C). Install bolts with threads to the inside of the machine.
3. Tighten bolts until pivot brackets contact ends of hinge.
4. Apply a spray lubricant to the pivot hardware, hinges, and pivot brackets.
5. To install support rod, have a second person raise and hold cargo box securely.

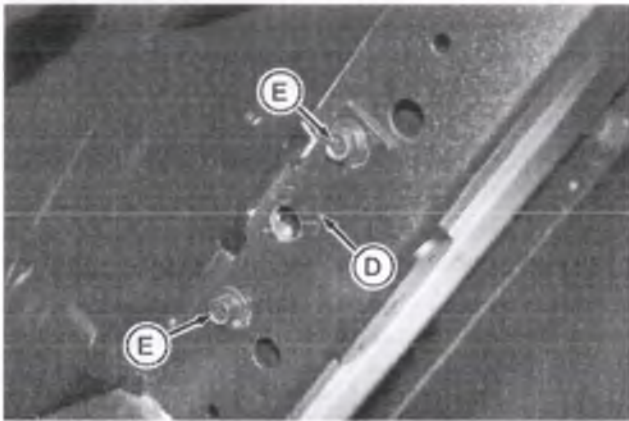

MXT020713—UN—08AUG17

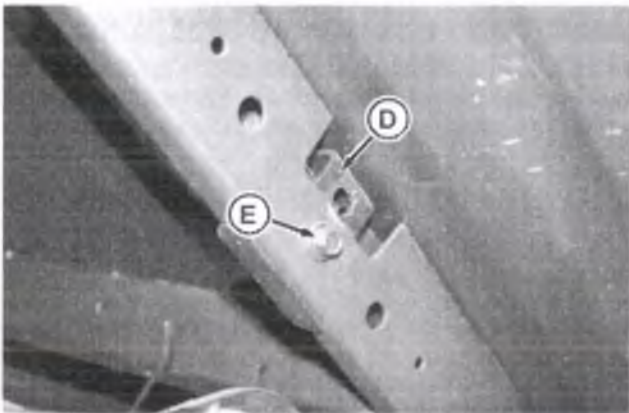

MXT020714—UN—08AUG17

6. Install support rod bracket (D) to the cargo box frame using three M8x20 self-tapping screws (E).



MXT020715—UN—08AUG17

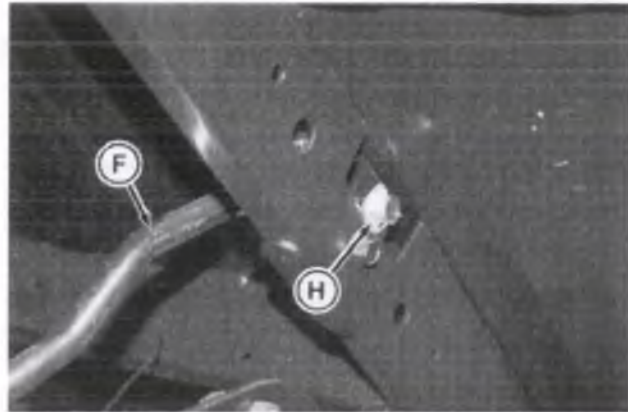

MXT020716—UN—08AUG17

7. Install 90° end (F) of the support rod into hole (G) in bracket, as shown. To secure the top end of the rod, install push-on nut (H).
8. Lower opposite end of the support rod, and push inward on rod forcing it over sill (I).
9. Install end (J) of the support rod into slot (K).

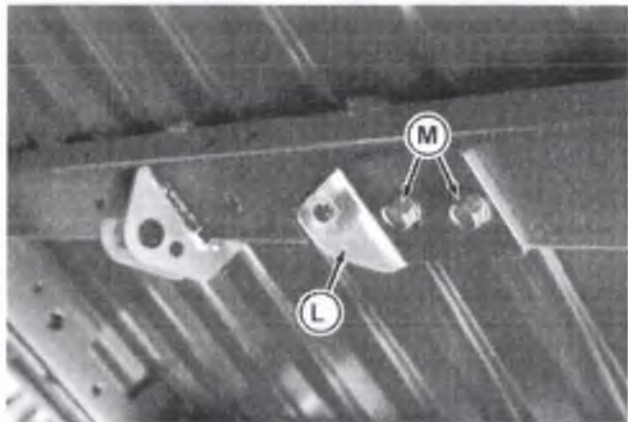

MXT020717—UN—08AUG17

10. Install upper mounting bracket (L) to the cargo box using two M8x20 self-tapping screws (M).

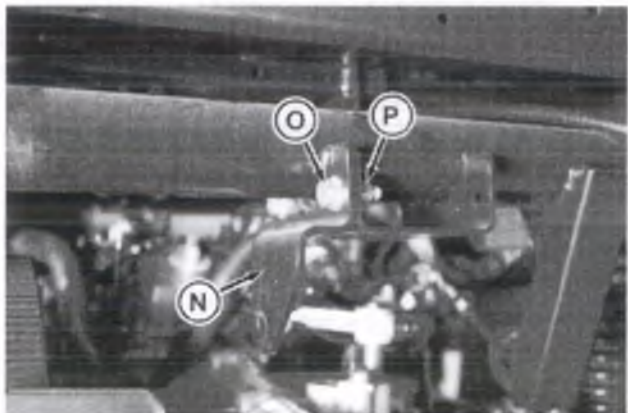

MXT020718—UN—08AUG17

11. Install lower mounting bracket (N) to the machine frame using two M8x20 bolts (O) and two M8 lock nuts (P).

Assembly

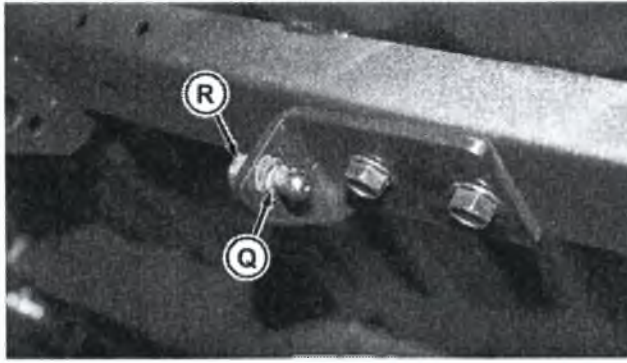

MXT020719—UN—08AUG17

Upper mounting bracket shown.

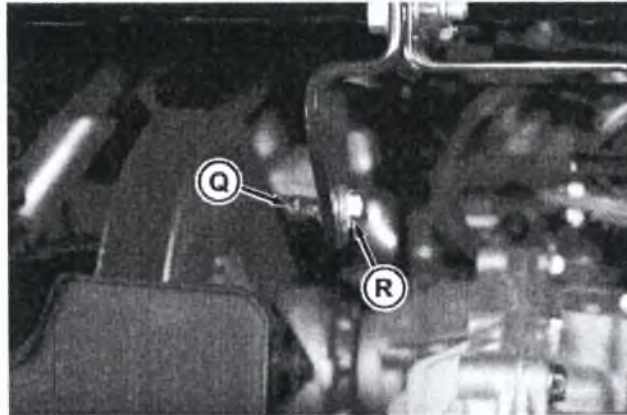

MXT020720—UN—08AUG17

Lower mounting bracket shown.

12. Install ball studs (Q) to upper and lower mounting brackets using M8 lock nuts (R).

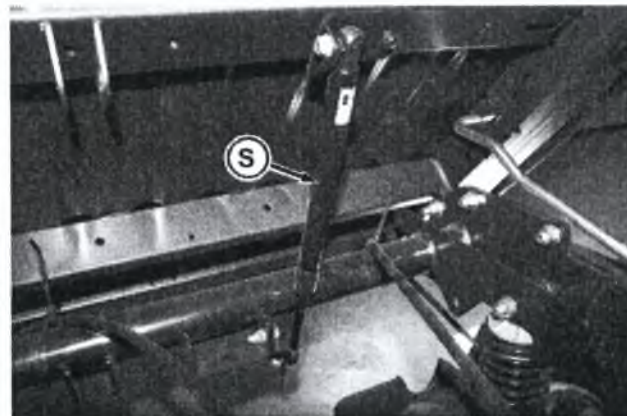

MXT020721—UN—08AUG17

13. Install gas cylinder (S) to ball studs, as shown.
14. Push down and lower the cargo box until the latch engages with an audible snap.

MX10673,0000067-19-08AUG17

Clean and Polish Plastic Hood and Fenders

IMPORTANT: Avoid damage! Improper care of machine plastic surfaces can damage the surface:

- Do not wipe plastic surfaces when they are dry. Dry wiping will result in surface scratches.
- Use only cheesecloth for wiping surfaces.
- Do not use abrasive materials, such as polishing compounds, on plastic surfaces.
- Do not spray insect repellent near machine.

1. Remove any dust or dirt with water.
2. Dry thoroughly to avoid water spots
3. Wax the surface with a liquid automotive wax. Use products that specifically say "contains no abrasives."

IMPORTANT: Do not use a power buffer to remove wax.

4. Buff applied wax by hand using a clean, soft cloth.

OUO2005.0000213-19-27SEP13

Check Fluid Levels

- Check all fluid levels.

OUO2005.0000214-19-27SEP13

Check Machine Safety System

Perform safety system check to make sure the electronic safety interlock circuit is functioning properly. Perform all tests. (See Testing Safety System in the OPERATING section.)

MP47322,00F462C-19-15MAR13

Burnish Brakes

⚠ CAUTION: Avoid injury! Test a machine under safe conditions. Perform this procedure in a clear open area. Keep bystanders away. Do not attempt any maneuvers that could jeopardize vehicle control. Failure to adhere to these precautions could lead to machine damage, serious personal injury, or death.

1. Park the vehicle safely.
2. Check tire pressure.
3. Check brake fluid level; add if necessary.
4. Start machine, and shift transmission into low range.
5. Disengage traction assist.
6. Disengage all-wheel drive.
7. Accelerate machine up to full throttle in high range.

Assembly

IMPORTANT: Avoid damage! Use care to avoid overheating brakes while performing the next step. Do not allow brakes to lock.

8. Using moderate pressure, apply brakes to bring the machine to a complete stop.
9. Repeat steps seven and eight 10 more times.

MX10673 000068-19-07AUG17

Machine Cleanout

General Cleaning Guidelines

Machine must be inspected periodically throughout the day. Buildup of debris must be removed to ensure proper machine function and to reduce the risk of fire. Frequency of these inspections and cleanings will vary depending on a number of factors including operating conditions, machine configuration, operating speeds, and weather conditions. Inspections and cleanings may be required multiple times throughout the day particularly in dry, hot, and windy conditions.

IMPORTANT: Regular and thorough cleaning of machine combined with other routine maintenance procedures listed in the Operator's Manual greatly reduce the risk of fire, downtime and improve machine performance.

Besides proper maintenance the condition of the material being handled is the most significant factor contributing to fires. Dry, light and fluffy materials that can create a dust cloud are the most likely to catch fire. Debris can accumulate in various areas especially on horizontal surfaces. Conditions such as wind speed and direction can change where the material accumulates. Be aware of these changing conditions and adjust your cleaning schedule and practices to ensure proper machine function and to reduce the risk of fire.

Always follow all safety procedures posted on the machine and in the Operator's Manual. Before carrying out any inspection or cleaning, always shut OFF engine, set parking brake and remove key.

The entire machine should be inspected, with extra attention given to the areas noted below.

OUMX068.0001043-19-10MAY17

Cleanout Areas

Primary areas that must be inspected and cleaned on the machine include (See Safety Label Section):

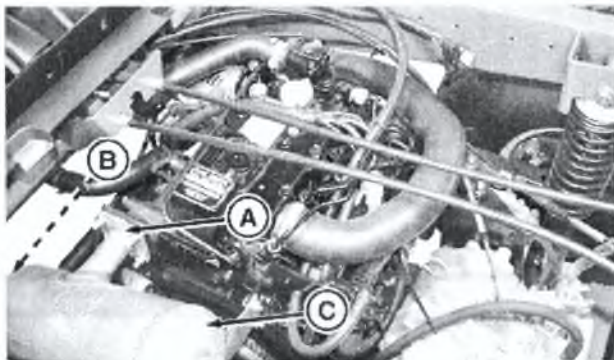

MXT008918—UN—11SEP13

- A. Exhaust manifold (A), muffler pipe (B), and muffler (C).

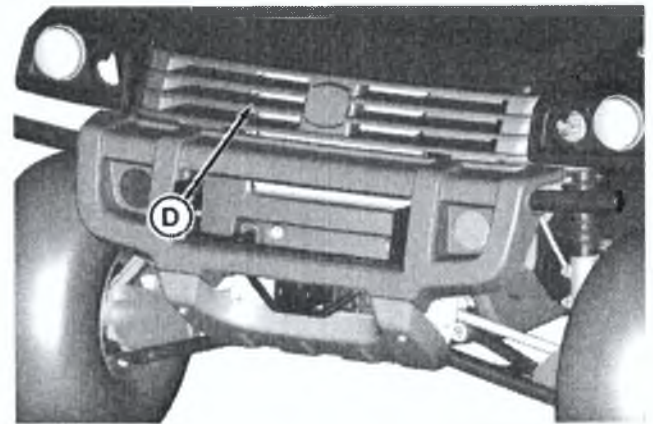

MXT020284—UN—14JUL17

- B. Upper grille screen (D).

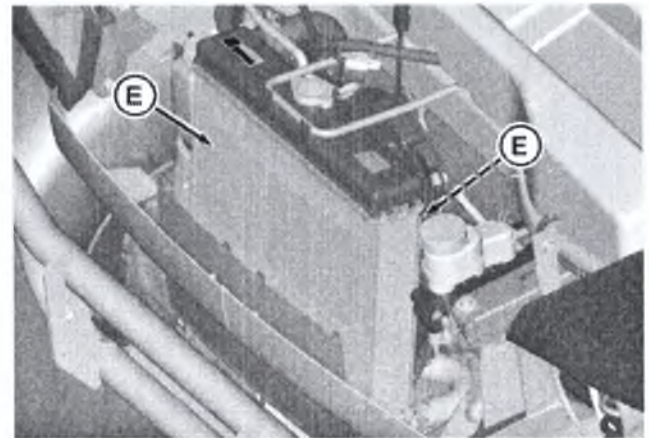

MXT014774—UN—23JUN15

- C. Radiator cooling fins (E).

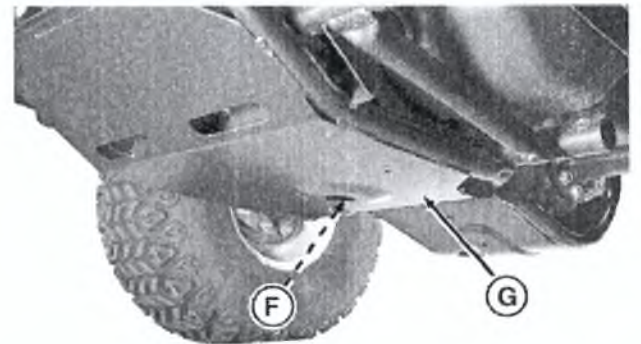

MXT008920—UN—11SEP13

- D. Between engine (F) and skid plate (G) (if equipped).

Machine Cleanout

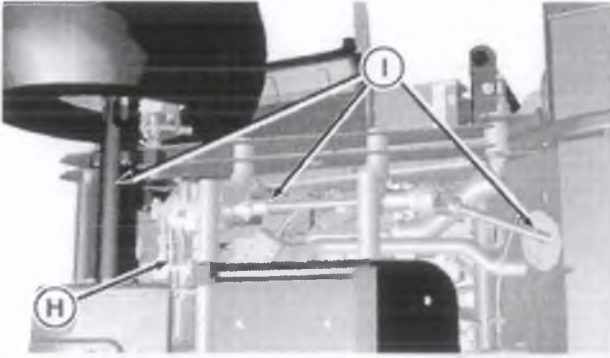

MXT008921—UN—11SEP13

- E. On or near transmission (H) and driveline (I).

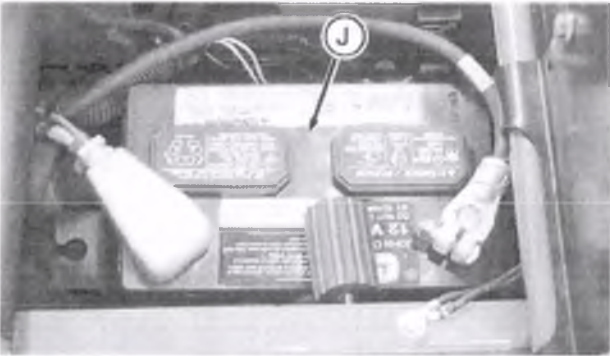

MXT008922—UN—11SEP13

- F. Battery (J) and related wiring harnesses.

OUMX068.000132E-19-14JUL17

Operating Controls

Operator Station Controls

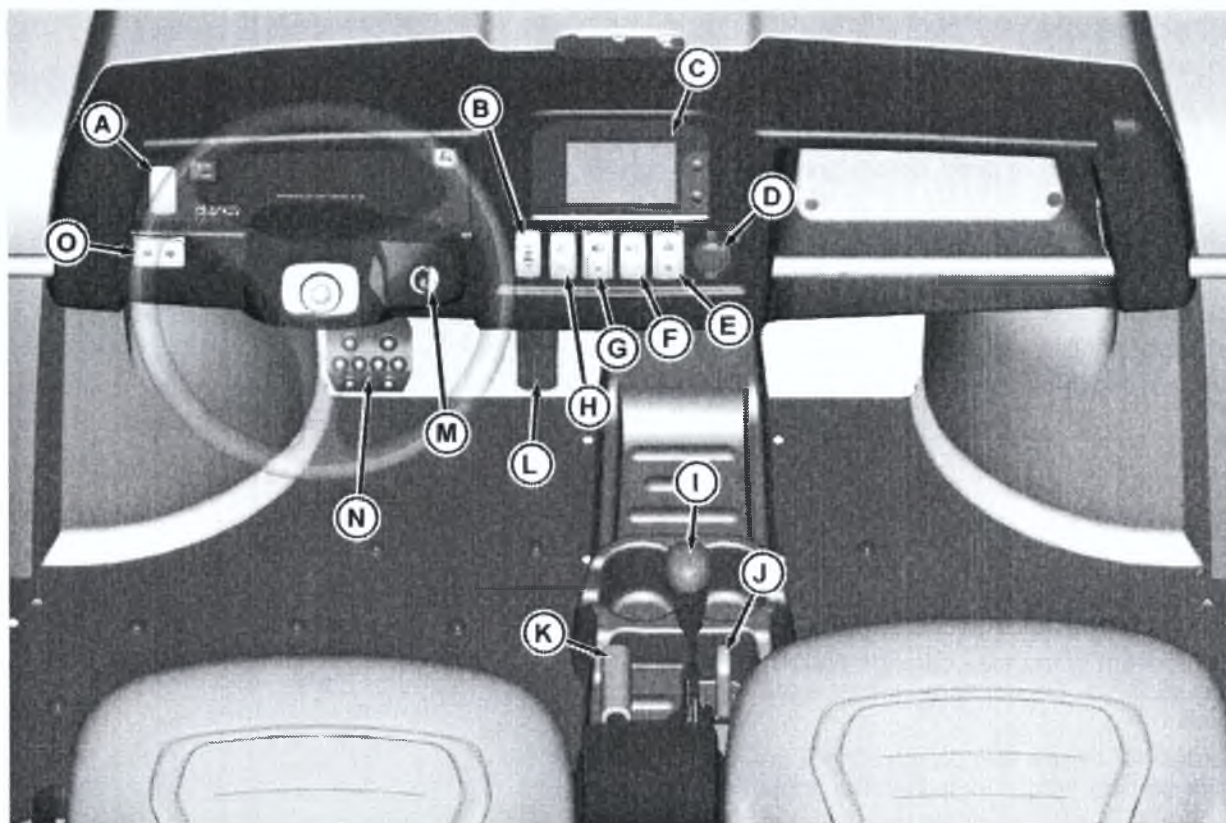

MXT020245—UN—27JUN17

Some controls may not be installed on your machine.

Key	Description	Key	Description
A	Cargo Box Power Lift Switch	I	Transaxle Shift Lever
B	2WD / 4WD Switch	J	Traction Assist (Differential Lock) Lever
C	Instrument Cluster Controller	K	Park Brake Lever
D	12V DC Accessory Outlet	L	Accelerator Pedal
E	Hazard Lights Switch	M	Ignition Key Switch
F	Horn Switch	N	Brake Pedal
G	Headlight Switch - High Beam	O	Turn Signal Switch
H	Headlight Switch - Low Beam		

OUMX068.00012F7-19-27JUN17

Operating

Daily Operating Checklist

- Test safety systems.
- Check tire pressure.
- Check fuel level.
- Check engine oil level.
- Remove grass and debris from engine compartment, muffler area, and front grille, before and after operating machine.
- Check area below machine for leaks.
- Check brakes and park brake operation.
- Check coolant level.
- Check air restriction indicator.
- Tighten any loose hardware.

JG81906.00006F7-19-01APR13

Avoid Damage to Plastic and Painted Surfaces

- Do not wipe plastic parts unless rinsed first. Using a dry cloth may cause scratches.
- Insect repellent spray may damage plastic and painted surfaces. Do not spray insect repellent near machine.
- Be careful not to spill fuel on machine. Fuel may damage surface. Wipe up spilled fuel immediately.
- Prolonged exposure to sunlight will damage hood surfaces.

JG81906.00006F8-19-01APR13

Using Doors or Nets

CAUTION: Do not operate vehicle with doors or nets removed. Always park vehicle safely before opening door or net to exit.

Do not operate vehicle with doors or nets in the open position. All doors or nets must be closed while the vehicle is in use.

Using Doors

Entering vehicle:



MXT008451—UN—27AUG13

1. Pull handle (A) toward you to unlatch and open door.
2. After entering the vehicle, check to be certain the door is securely latched.

Exiting vehicle:

1. Park vehicle safely.



MXT008449—UN—27AUG13

2. Pull handle (A) toward you to unlatch and open door.
3. After exiting the vehicle, check to be certain the door is securely latched.

Using Nets

Entering vehicle:

1. Move net rearward out of entry and exit area, and enter vehicle.

Operating



MXT008444—UN—27AUG13

2. Move net forward and insert metal tab of net into buckle (A) until it latches.
3. After entering the vehicle, check to be certain the net is securely latched.

Exiting vehicle:

1. Park vehicle safely.
2. Push button to release metal tab from buckle (A).
3. Move net rearward out of entry and exit area, and exit vehicle.

MX10673,000025-19-19JUL17

Using Hand Holds

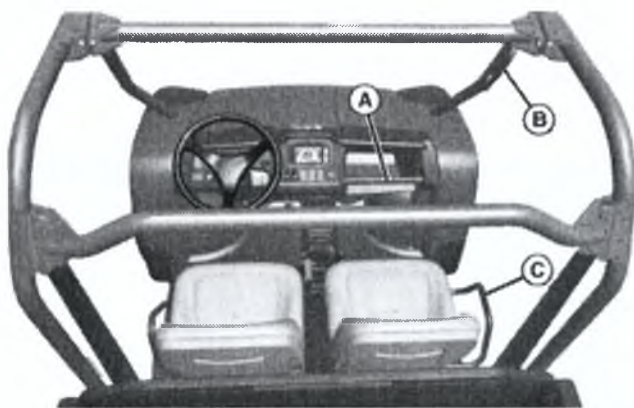

MXAL42901—UN—15MAR13

Hand holds are provided for passenger balance. When a passenger is present, they shall use two of the three hand holds at all times while the machine is moving. The dash bar (A), OPS handle (B), and side rail (C).

JG81906,00006F9-19-01APR13

Adjusting Operators Seat

⚠ CAUTION: Avoid injury! Never adjust seat while machine is moving. Stop machine before adjusting seat to prevent loss of machine control.

1. Stop machine and move transaxle shift lever to N (neutral) position.
2. Lock park brake.

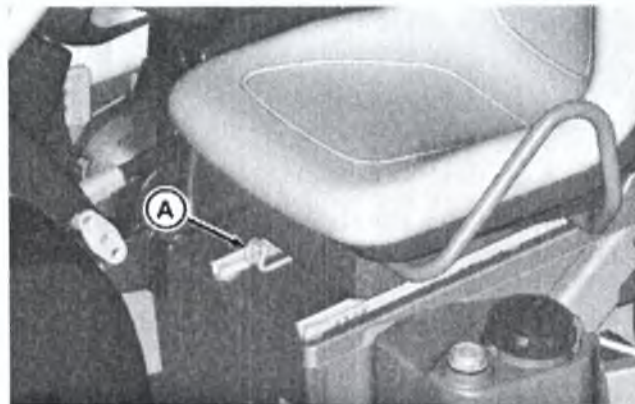

MXT014775—UN—23JUN15

3. Push lever (A) to the left.
4. Slide seat forward or rearward to desired position.
5. Release lever.

OUMX068,0000C45-19-26JUL17

Using Seat Belt

NOTE: Shoulder harness is sensitive. An emergency lock device is built into the belt for your protection. To engage harness, pull harness slowly. Attempting to pull too fast or in a jerking motion engages the locking mechanism and the harness does not release.

Periodically inspect seat belts for wear or damage. See Inspecting Seat Belt in SERVICE MISCELLANEOUS.

Operating

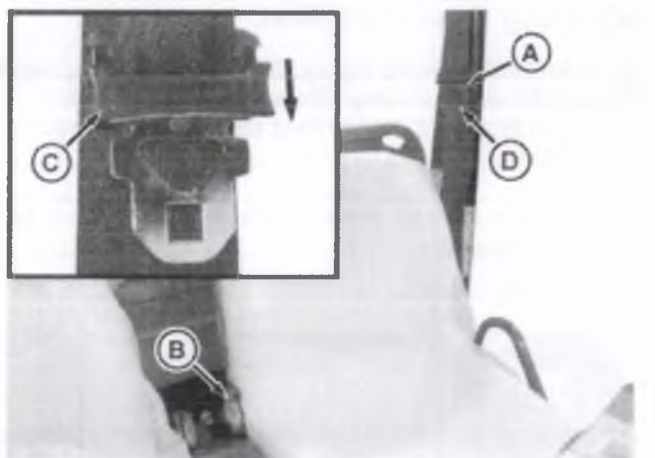

Fasten Belt

1. Grasp outer seat belt connector (A) from behind seat, pull out and across body to inner connector (B), at inside of seat.
2. To adjust outer connector up or down along belt for best fit:
 - a. Grasp lower portion (C) of tongue by outer edges.
 - b. Slide down as indicated by arrows molded into plastic.
 - c. Once best fit is achieved, slide lower portion back up to lock.
3. Push outer connector lower half (D) firmly into inner connector until it locks.
4. Snug the seat belt across the hips, on top of the thighs.

Release Belt

1. Press red button on inner connector to release seat belt.

OUMX068.0000C4B-19-23JUN15

Testing Safety Systems



⚠ CAUTION: Engine exhaust fumes contain carbon monoxide and can cause serious illness or death.

- Move the machine to an outside area before running the engine.
- Do not run an engine in an enclosed area without adequate ventilation.
- Connect a pipe extension to the engine exhaust pipe to direct the exhaust fumes out of the area.
- Allow fresh outside air into the work area to clear the exhaust fumes out.

The safety systems installed on your machine should be checked before each machine use. Be sure you have read the machine operator manual and are completely familiar with the operation of the machine before performing these safety system checks.

Use the following checkout procedures to check for normal operation of machine.

If there is a malfunction during one of these procedures, do not operate machine. **See your authorized dealer for service.**

Perform these tests in a clear open area. Keep bystanders away.

JG81906.00006FD-19-01APR13

Testing the Safety Start System

NOTE: The engine can start with the transaxle in gear. The machine has a brake pedal safety start switch. The brake pedal must be pushed down to start the engine.

1. Sit on the operator's seat.
2. Put key switch in OFF position.
3. Lock park brake.
4. Move transaxle shift lever forward to N (Neutral) position.
5. Turn key switch to start position. Engine should not crank. Turn key switch off.
6. Push down on brake pedal.
7. Turn key switch to start position. Engine should crank, allowing engine to start.
8. Allow engine to run a few seconds.
9. Turn key switch off.

MX10673.0000061-19-06AUG17

Operating

Using Park Brake

NOTE: Park brake alarm will buzz if the machine is in gear and you try to move in forward or reverse before unlocking the park brake.

CAUTION: Children or bystanders may attempt to move or operate an unattended machine.

Always lock the park brake and remove the key before leaving the machine unattended.

IMPORTANT: Damage to brake will occur if machine travels with brake locked.

Unlock park brake before beginning machine travel.

Locking the Park Brake:

1. Push down on brake pedal to hold machine in place.
2. Pull up on lever to engage park brake.

Unlocking the Park Brake:

1. Push down on brake pedal to hold machine in place.
2. Pull up on lever.
3. Press center button on lever, and release lever down completely.

JG81906.00006FF-19-05APR13

Using Ignition Key Switch

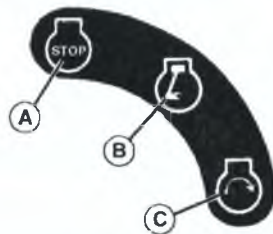

Ignition key switch label

MXAL42906—UN—15MAR13

A - STOP Position - With key in STOP position, all switched power is off, and engine should not run.

B - RUN Position - Turn key from STOP to this position and all switched power circuits will be on.

C - START Position - Depress the brake pedal and turn key to START position to crank the engine. Release key after engine has started and it will automatically return to the RUN position. The engine will continue to run.

MX10673.0000065-19-07AUG17

Using Headlights

Key switch must be in the run position to operate the lights. If the key switch is in the run position and the engine is not running, the battery will discharge if the lights are allowed to remain on for an extended period of time.

- Press at top of light switch to turn headlights on.
- Press at bottom of light switch to turn headlights off.

JG81906.0000701-19-01APR13

Using Instrument Cluster Controller

NOTE: Depending on the machine model, some functions are not available.

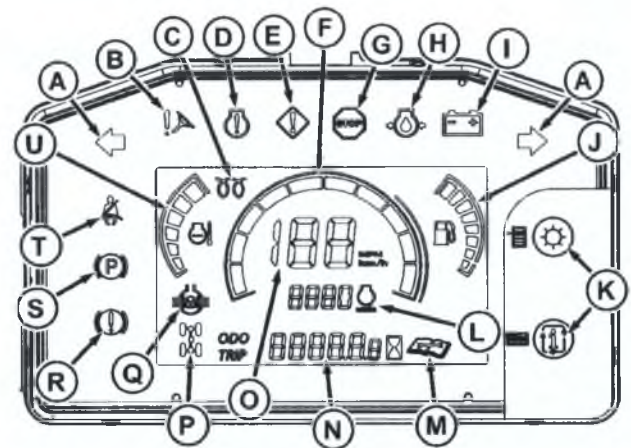

MXT020153—UN—17MAY17

Some indicators may not be displayed on your machine.

A - Turn Signal Indicator - The left or right signal indicator flashes when turn signal is active.

B - Electric Power Assist Steering (EPAS) Malfunction Indicator - This indicator illuminates or flashes when the EPAS system detects a fault. The level of assist may also be decreased.

C - Glow Plug Indicator - The indicator illuminates while the glow plugs are heating after the key switch is placed in the RUN position. Depending on the temperature, the indicator turns off in approximately 0-10 seconds indicating that the engine can be started.

D - Engine Malfunction Indicator - This indicator illuminates or flashes when an engine fault has been detected.

E - Operator Alert Indicator - This indicator illuminates when a fault has been detected that does not require the machine to be stopped immediately.

F - Speedometer/Engine RPM Gauge - The bar gauge can be set to show engine or wheel speed.

G - Stop Indicator - This indicator illuminates or flashes

Operating

alerting the operator to a condition that requires immediate attention and to stop the machine.

H - Low Engine Oil Pressure Indicator - This indicator illuminates or flashes when the engine is running and the engine oil pressure is too low.

I - Battery Indicator - This indicator illuminates or flashes when a low or high voltage has been detected. Turn off electrical loads.

J - Gas Gauge - The bar graph has eight segments representing actual fuel level. Each bar displays approximately 1/8 of a full fuel tank. If there is less than 1/8 of a tank (no bars illuminated) the gas symbol blinks.

K - Instrument Cluster Controller Buttons - These buttons are used to activate certain instrument cluster controller functions. For detailed instructions, see Using Instrument Cluster Controller Buttons in OPERATING Section.

L - RPM Gauge - This gauge shows a digital readout of the current engine RPM value

M - System Diagnostic Indicator - This indicator illuminates or flashes for system malfunctions that do not have a specific indicator.

N - Odometer, Trip Meter, Hour Meter Gauge - This indicator shows the accumulated kilometers/miles the machine has traveled, along with a trip meter. The hour meter portion shows the accumulated number of operating hours the engine has run. The hour meter displays operating hours and accumulates and displays operating hours when the engine is running. The hour meter is intended to provide a means of monitoring machine usage for maintenance purposes. Use the hour meter to determine when your machine has reached the recommended service intervals.

O - Speedometer - The speedometer indicates machine speed in km/h or mph.

P - 4WD Indicator - This indicator illuminates when four-wheel drive is enabled.

Q - Differential Lock Indicator - This indicator illuminates when the differential lock is engaged.

R - Brake System Alert Indicator - This indicator illuminates when the brake fluid falls below the acceptable level.

S - Park Brake Indicator - This indicator illuminates when the park brake is partially or fully engaged.

T - Seat Belt Indicator - This indicator illuminates or flashes when the driver seat belt is not secured.

U - Coolant Temperature Gauge - This gauge displays the current engine temperature. If the temperature rises to an overheat condition, the stop indicator (G) illuminates.

Equipment for Road Homologated Machines

X - Denotes which indicators in the instrument cluster are active based on the machine model.

O - Denotes which indicators in the instrument cluster are optional based on the machine model.

Indicators	HPX815E
Turn Signal	X
Electric Power Assist	
Glow Plug (Diesel only)	X
Engine Malfunction	
4WD	
Differential Lock	
Brake System Alert	X
Low Engine Oil Pressure	X
Gas Gauge	
RPM Gauge	
Coolant Temperature Gauge	

OUMX068.0001325-19-17JUL17

Using Instrument Cluster Controller Buttons

1. Turn the key switch to run position.

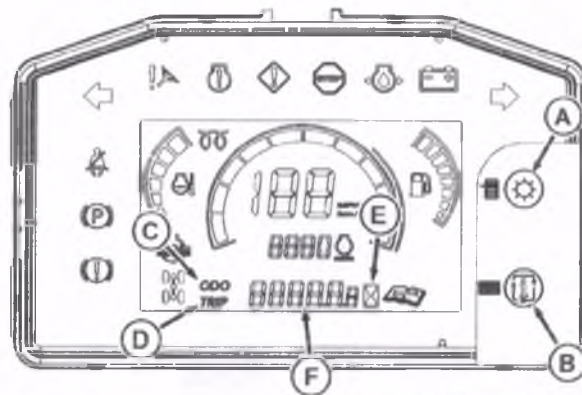

MX019881—UN—17FEB17



MX020182—UN—15JUN17

Display Brightness Screen

2. Adjust the display brightness by pressing the select button (A).

Operating

Odometer, Trip Meter, and Hour Meter

Toggle between odometer, trip meter, and hour meter Home screens by pressing the cycle button (B).



MXT020183—UN—15JUN17

- When "ODO" (C) is displayed, the odometer indicator (F) displays the number of miles or km the machine has moved. (To change between miles or km displayed, see System Settings Menu.)



MXT020184—UN—15JUN17

- When "TRIP" (D) is displayed, the indicator (F) displays the number of miles or km the machine has moved for a certain trip. (To change between miles or km displayed, see System Settings Menu.)



MXT020185—UN—15JUN17

- When the hour meter (E) is illuminated, the indicator (F) displays the number of operating hours the engine has run.

System Settings Menu

To enter the System Settings Menu from the Home screen, press and hold the select button (A) for the required time. Pressing the cycle button (B) toggles through the Tire Size, Display Units, Speed Units, and two Diagnostic Trouble Codes (DTC) menus. (DTC menus are provided for diagnosing a machine malfunction. See your John Deere dealer for service.)

NOTE: If vehicle speed is greater than 4.8 km/h (3 mph), no menu settings are allowed.

NOTE: While in a main or sub menu item, if no button is pressed within the required time, the settings menu returns to the current Home screen. Press and hold the select button for the required time to get back to the settings menus.

Tire Size Selection Menu



MXT019883—UN—17FEB17

14 inch Tire Size Shown

This menu allows the operator to adjust for the tire sizes available. The current setting is displayed on the lower seven segment section when entering the option menu structure.

To enter the tire size menus, press the select button (A). To toggle through and display the tire sizes, press the cycle button (B). The tire size value displayed flashes every 1 second. When the desired tire size is displayed, press the select button. The tire size remains solid on for 1 second, and then the display returns to the Main Menu for this setting.

Display Units Selection Menu



MXT019884—UN—17FEB17

English Display Units Shown

This menu allows the operator to select either English or metric units when applicable. The current setting is displayed on the lower seven segment section when entering the option menu structure.

To enter the display units menus, press the select button (A). To toggle between US/mph and SI/km/h, press the cycle button (B). The display unit text and icon flashes every 1 second. When the desired display unit is displayed, press the select button. The display unit text and icon remains solid on for 1 second, and then the display returns to the Main Menu for this setting.

Operating

Engine RPM/Speedometer Gauge Selection Menu



MXT019885—UN—17FEB17
Vehicle Speed Option Shown

This menu allows the operator to change the center bar graph to show a graphical representation of either the vehicle speed or engine rpm. On the Home screen, an icon identifies which option is selected. The current setting is displayed on the lower seven segment section when entering the option menu structure. "CYC" identifies the gauge as being in the engine tachometer mode. The "SP" identifies the gauge as being in the vehicle speedometer mode. Both modes show a graphical approximation of the selected mode.

To enter the engine rpm/speedometer menus, press the select button (A). To toggle between SP/MPH and CYC/rpm, press the cycle button (B). The display unit text and icon flashes every 1 second. When the desired display unit is displayed, press the select button. The display unit text and icon remains solid on for 1 second, and then the display returns to the Main Menu for this setting.

OUMX068 000129D-19-20JUL17

Exit Lighting Operation

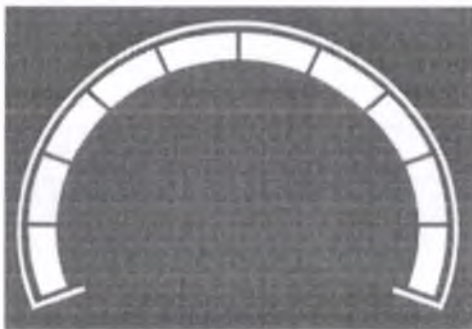

MXT019886—UN—17FEB17
Countdown Timer

Function

A method for a "soft" shutdown of lighting after the key switch is turned off.

Operation

When the key switch is turned off, certain circuits remain

on. The countdown timer bar display represents circuit power removal.

OUMX068 000123B-19-20JUL17

Using Accessory Outlet

CAUTION: Safe operation requires your full attention. Do not wear radio or music headphones while operating machine.

NOTE: Accessory must be rated at 10 amps or less.

The accessory plug does not turn off with the key switch. Items connected to the accessory plug will continue to draw power draining the battery.

- Remove 12-volt outlet cover and install accessory cord in outlet.
- Install cover in outlet after use.

JG81906 0000703-19-05APR13

Using Turn Signal Switch (If equipped)

NOTE: Turn signals will continue to flash when the key is in the off position, draining the battery.

- Press at left end of turn signal switch to signal a left turn.
- Press at right end of turn signal switch to signal a right turn.
- Press at opposite end of turn signal switch until switch is centered to turn signal light off.

JG81906 0000704-19-01APR13

Using Hazard Lights (If equipped)

NOTE: Hazard lights will continue to flash when the key is in the off position, draining the battery.

- Press at top of hazard light switch to turn hazard lights on.
- Press at bottom of hazard light switch to turn hazard lights off.

JG81906 0000705-19-01APR13

Using Storage Tray

CAUTION: Never store flammable, heavy, or loose breakable objects in the storage tray. Always latch hood before operating machine.

Operating

IMPORTANT: Do not store items that will not allow the hood to close properly. Properly secure loose or sharp items. These items may damage the storage tray or other items within the tray.

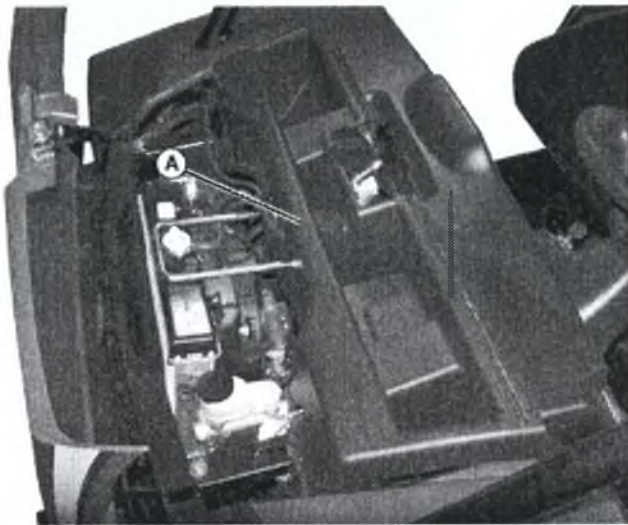

MXAL42908—UN—15MAR13

Storage tray (A) is located in front of machine under the hood.

1. Open hood to access the storage tray.
2. Secure all items to prevent damage from movement while operating the machine.
3. Close hood.

JG81906,0000706-19-01APR13

Starting the Engine

! **CAUTION:** Engine exhaust fumes contain carbon monoxide and can cause serious illness or death.

- Move the machine to an outside area before running the engine.
- Do not run an engine in an enclosed area without adequate ventilation.
- Connect a pipe extension to the engine exhaust pipe to direct the exhaust fumes out of the area.
- Allow fresh outside air into the work area to clear the exhaust fumes out.

1. Sit on operator seat. Do not start engine at this time.
2. Push down on accelerator pedal to check free movement of pedal assembly. Release pedal.
3. Verify that transaxle shift lever is in N (Neutral) position.
4. Verify that park brake is locked.

! **CAUTION:** Do not start engine by shorting across starter terminals. Bypassing normal circuitry will allow vehicle to start in gear.

Do not use starting fluid to aid engine starting.
Never start engine while standing on ground.
Start engine only from operator's seat.

NOTE: The engine can start with the transaxle in gear. The machine has a brake pedal safety start switch. The brake pedal must be pushed down to start the engine.

On some machine models, starter crank protection may engage and you will be unable to crank the engine for approximately ten seconds.

5. Push and hold the brake pedal down to engage the safety start switch.
6. Turn key switch to the ON position.
7. Check that the following indicator lights are on:
 - battery discharge light
 - oil pressure light
 - glow plug/coolant temperature light for approximately 3 - 5 seconds
8. When the glow plug/coolant temperature light turns off, turn key to START position.

IMPORTANT: Starter may be damaged if operated continuously for extended periods of time. Allow starter to cool down after several starting attempts.

9. Release key to the ON position when engine starts.
 - If engine does not start within five seconds, turn key to OFF position and wait ten seconds before trying to start again.
 - Attempt starting engine five times only, then wait 5 minutes before trying again. This will allow time for starter to cool and prevent damage to starter.

IMPORTANT: Avoid damage! Do not operate the engine at full throttle or under load until engine has warmed up, or engine damage could occur.

10. Run engine at half speed for 2 or 3 minutes to warm the engine.

MX10673,0000062-19-08AUG17

Stopping Engine

! **CAUTION:** Children or bystanders may attempt to move or operate an unattended machine.

Operating

Always lock the park brake and remove the key before leaving the machine unattended.

IMPORTANT: Do not stop engine immediately after hard or extended operation. Keep engine running at low idle for about 2 minutes to prevent heat build-up.

1. Stop machine.
2. Move transaxle shift lever to N (Neutral) position.
3. Lock park brake.
4. Turn ignition key switch to OFF position.
5. Remove key.

JG81906.0000708-19-01APR13

Emergency Stopping

1. Remove foot from travel pedal or accelerator pedal.
2. Depress brake pedal. Do not release brake pedal until machine has stopped.
3. After machine has stopped, lock the park brake.
4. Turn ignition key switch to STOP position.

JG81906.0000709-19-01APR13

Using Travel Controls

1. Stop machine.
2. Allow engine to come to a low idle speed.

IMPORTANT: Do not shift gears when vehicle is moving or with engine running above low idle speed. Push down brake to stop vehicle motion and engage shift lever with a firm positive action.

Gears may grind when shifting if engine idle speed is set higher than factory specification.

NOTE: Always shift into low range when operating on wet or uneven terrain, or when towing or pushing heavy loads.

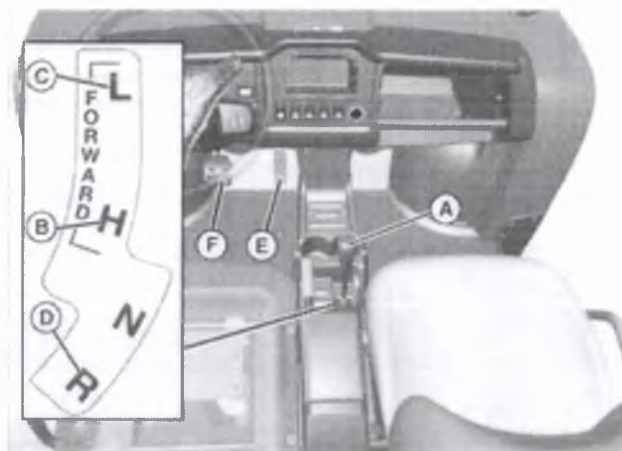

3. Select a gear position:
 - Forward - Push shift lever (A) forward to either high (B) or low (C) range.
 - Reverse - Push shift lever to left, then pull rearward to reverse (D) gear.
 4. Look in the direction the vehicle will travel.
- CAUTION:** Reduce speed before braking or turning, when hauling loads, and while operating around obstacles or on hazardous off-road conditions.
5. Push down accelerator pedal (E) slowly and smoothly to begin machine travel.
 6. Release accelerator pedal and apply brake pedal (F) evenly and firmly to slow down or stop.

JG81906.000070A-19-08APR13

Using Traction Assist

Traction assist provides better traction when rear wheels start to slip. Engaging the traction assist will cause both rear wheels to turn together at equal speed.

CAUTION: Driving at high speeds with the traction assist engaged may result in loss of steering control. Do not engage traction assist or turn with the traction assist engaged while operating machine at high speeds or on slopes.

Engaging the Traction Assist:

IMPORTANT: Incorrectly engaging traction assist may damage the transaxle.

Reduce speed before engaging or disengaging traction assist.

1. Stop or reduce engine speed to 1/3 throttle or less.
2. Pull traction assist lever up to the locked (vertical) position:

Operating

- Traction assist will remain engaged as long as lever is up (vertical).

Disengaging the Traction Assist

NOTE: To ensure true disengagement of traction assist, you must equalize torque on both axles.

1. Stop or reduce engine speed to 1/3 throttle or less.
2. Drive the vehicle straight ahead at a constant speed.
3. Push lever down to unlocked position.

JG81906,000070B-19-08APR13

Using Four Wheel Drive

4WD On-Demand enables the front wheels to drive, but torque will not be applied until rear wheels begin to slip.

CAUTION: 4WD On-Demand greatly increases traction and may make dangerously sloped terrain accessible, increasing possibility of a tip-over.

Use extra caution when driving on slopes. Use 4WD On-Demand when driving on slopes to increase traction.

Use 4WD On-Demand when driving on icy, wet or graveled surfaces; reduce speed to avoid skidding and loss of steering control.

IMPORTANT: Engaging 4WD On-Demand when the machine is stopped and the rear wheels are spinning will damage the gears.

- Push in on top of 2WD/4WD switch to enable the 4WD On-Demand system.
- Push in on bottom of switch to disable the system.

CAUTION: Front implements may cause decreased traction at the rear wheels resulting in loss of control. Always operate machine with 4WD On-Demand engaged when front implements are attached.

Tips for operating 4WD On-Demand:

NOTE: Occasionally the 4WD On-Demand system will not disengage after a change in vehicle travel direction. This is known as "wedging." If this does occur, the vehicle will exhibit higher than usual steering efforts and driveline wind-up. To disengage (un-wedge) the system, reverse the direction of vehicle travel.

- Maintain recommended front and rear tire pressures to ensure optimum performance on all surface conditions.
- Disable 4WD On-Demand when driving machine on

paved or hard packed surfaces to increase front tire life and reduce drive train wear.

JG81906,000070C-19-05APR13

Using the Cargo Box

CAUTION: Avoid injury! Seating is provided for the operator and one passenger. Do not allow riders in the cargo box or on the tailgate. Extra riders can fall off and be seriously injured or killed.

Raising and Lowering with Manual Lift

CAUTION: Avoid injury! Park machine on a level surface and lock park brake before manually raising and securing cargo box in raised position.

A cargo box containing material is heavy. Empty some or all material until cargo box can safely be raised manually.

1. Park the vehicle safely. (See Parking Safely in the SAFETY section.)
2. Empty cargo box by hand.
3. Disengage cargo box lock if installed.

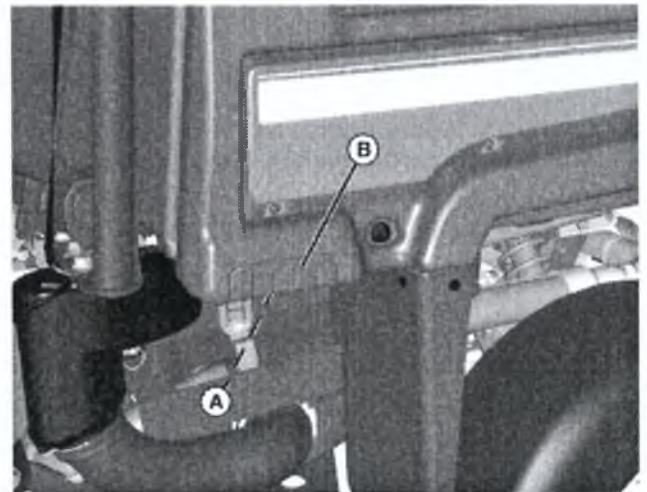

MXAL44170—UN—10APR13

4. To release pressure against latch (A), push down on cargo box.
5. Release latch by pulling latch towards grip (B) on cargo box. Allow lift cylinder to raise cargo box.

Operating

Raising and Lowering with Power Lift

IMPORTANT: Avoid damage! A hydraulic “whine” or squealing sound when cargo box is fully raised or lowered or when box is heavily loaded indicates that the power lift hydraulic overload pressure relief valve has opened, and the power lift can not apply any more force. To prevent unnecessary wear or damage, keep sound to a minimum. Do not operate the power lift actuator beyond full stroke or exceed the cargo box weight capacity.

1. Park the vehicle safely. (See Parking Safely in the SAFETY section.)
2. Disengage cargo box lock if installed.
3. Turn key to RUN position.
4. Raise the cargo box by pressing and holding the top of the cargo box power lift switch. Release switch when box is at desired dump height or when reaching maximum height.

NOTE: Allowing the pressure relief valve to open slightly (whine or squeal) after cargo box is fully lowered, helps keep the cargo box secure and reduce rattling caused by travel vibrations.

5. Lower cargo box by pressing and holding bottom of cargo box power lift switch.
6. Turn key to STOP position.

Operating the Tailgate

CAUTION: Avoid injury! Never operate tailgate with one lanyard attached (always use both).

Check condition of lanyards for wear or damage. Replace if cable is kinked or frayed.

IMPORTANT: Avoid damage! Do not attempt to tilt or dump cargo box when lanyards are detached. Tailgate damage from contact with hitch results.

To avoid jamming material in the gap between the cargo box bed and tailgate, keep lanyards attached when loading and unloading loose materials.

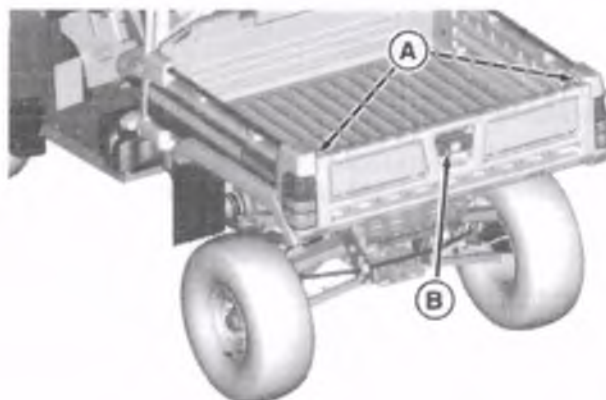

MXTO11039—UN—09SEP14

1. Check to be sure lanyards (A) are in place to support lowered tailgate.
2. Disconnect lanyards if you want to lower tailgate more than 90 degrees.

IMPORTANT: Avoid damage! Lower tailgate completely to unload cargo box only. Never drive with the tailgate hanging down. Tailgate can contact tires and cause damage.

3. Pull back on handle (B) to unlock and lower tailgate.
4. Before raising tailgate, check for stones and debris caught in the gap between the tailgate and cargo box floor.

To remove debris:

- a. Lock the cargo box in raised position.
 - b. Rotate the tailgate slightly to free debris, and brush out the gap.
 - c. Lower the cargo box.
5. To raise tailgate, slowly push tailgate upward and lock into closed position.
 6. Check to be sure that tailgate is securely locked.

Using Cargo Box Tie Downs

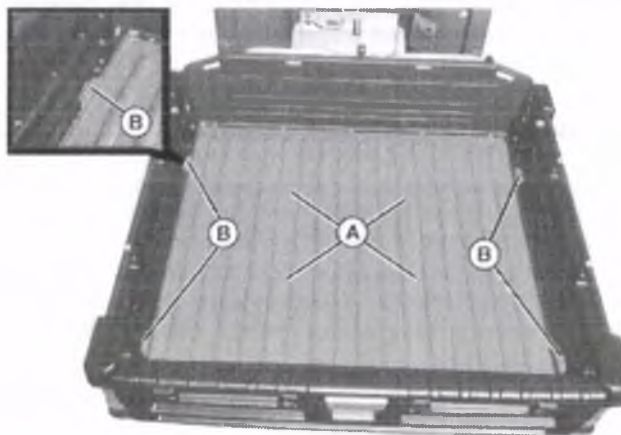

MXAL44173—UN—10APR13

1. Arrange load so the weight is centered over the main cargo area (A).

Operating

2. Secure loads to the tie-downs (B) in a safe and secure manner.

Removing the Tailgate

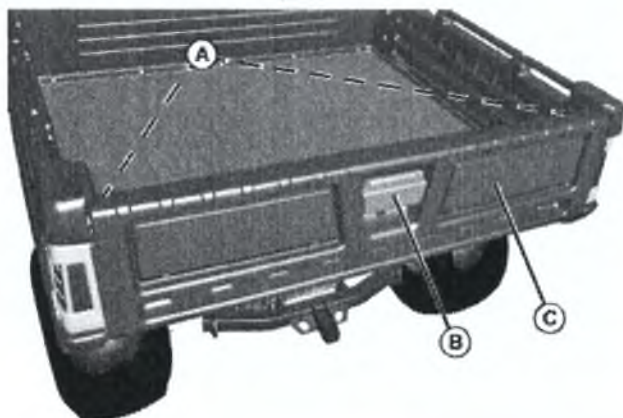

MXAL44174—UN—10APR13

1. Check to be sure lanyards (A) are in place to support lowered tailgate.
2. Pull back on handle (B) to unlock and lower tailgate (C).

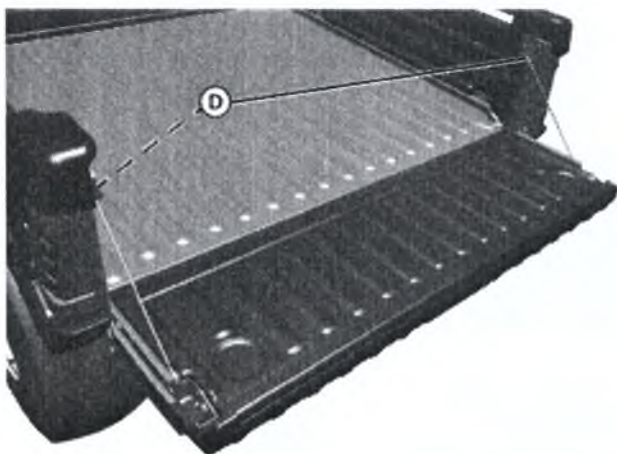

MXAL44175—UN—10APR13

3. Loosen loop (D) on top of lanyards, disconnect from studs on cargo box side, and lower tailgate fully downward.

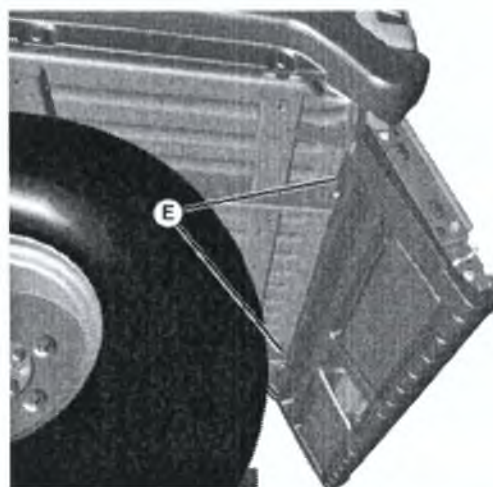

MXAL44176—UN—10APR13

4. Loosen two nuts (E) on rear of floor panel, to allow side panels to be removed.
5. If equipped with tail lights, disconnect the wiring harness and hang the harness in the rear of the box.

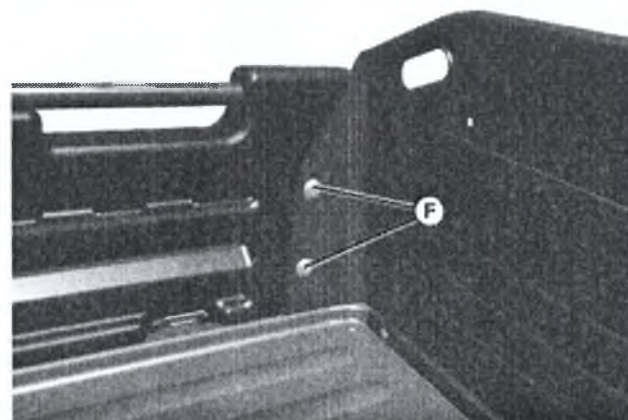

MXAL44177—UN—10APR13

6. From behind drivers seat in cargo box, remove two nuts (F).

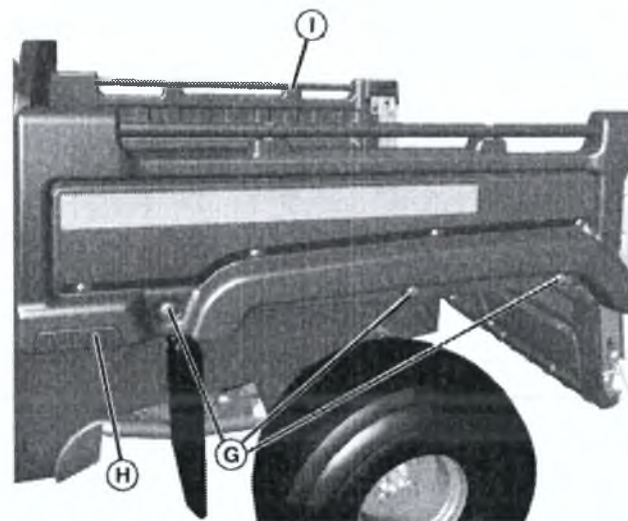

MXAL44178—UN—10APR13

Operating

7. Loosen three bolts (G) in left side body panel (H). Do not completely remove bolts from clamp-on nuts.
8. Support the tailgate to avoid bushing damage. Move side body panel slightly outward and remove tailgate from left side body panel and right side body panel (I).
9. Install in reverse order of removal.

MX10673.000063-19-07AUG17

Determining Vehicle Load Capacity

Find weights and capacities for your machine model in SPECIFICATIONS.

! CAUTION: Overloading the vehicle or trailer can cause loss of control and could cause serious injury or death.

- Do not allow the Gross Vehicle Weight (GVW) to exceed the Gross Vehicle Weight Rating (GVWR) of the vehicle.
- Remove excess weight before operating vehicle.

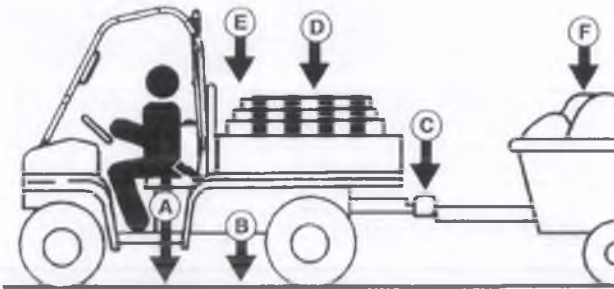

MXAL42921—UN—15MAR13

Factors in Determining Vehicle Load Capacity

NOTE: Optional equipment or attachments that are not standard equipment, must be included when determining gross vehicle weight, and may reduce cargo box capacity.

- **Gross Vehicle Weight (GVW)** is the combination of the empty vehicle weight, payload, trailer tongue weight, and the weight of any other kits or attachments on the vehicle.
GVW = A+B+C+D+E
- **Gross Vehicle Weight Rating (GVWR)** is the maximum permissible vehicle weight.
- **Payload** is the weight of all occupants plus the cargo box load.
- **(A) Occupant load** is the combined weight of all occupants (operator and one passenger).
- **(B) Empty vehicle weight** is the weight of the vehicle (full fluids) without occupant(s) or load or attachments.
- **(C) Trailer tongue weight** is the weight measured if

the tongue of a loaded trailer was placed on a scale. The tongue weight should be approximately 10% of the total of the trailer weight and the weight of its load.

- **(D) Cargo box load** is the weight of the cargo in the cargo box. It may be less depending on the weight of the occupants, attachments and the trailer tongue weight.
- **(E) Attachment and Option weight** is the combined weight of all attachments and options that were not standard equipment. Your John Deere dealer can help you with this information.
- **Vehicle Load capacity** is the remaining amount of weight that the vehicle can haul in the cargo box and/or the additional weight from the operator, passenger, trailer tongue and attachments.
- **Determine maximum vehicle load capacity:**
 - a. Calculate $GVW = A+B+C+D+E$
 - b. Subtract the Gross Vehicle Weight (GVW) from the Gross Vehicle Weight Rating (GVWR).
 - c. The weight difference between the two numbers is the vehicle load capacity.
Vehicle Load Capacity=GVWR-GVW
 - d. The Gross Vehicle Weight must be less than or equal to the Gross Vehicle Weight Rating. If GVW exceeds GVWR, remove excess weight from vehicle before operating.

Example:

The example below is for an HPX Diesel model with a 150 lb cargo load, a 200 lb operator, 220 lb of attachments and options (such as a heavy duty brush guard, OPS poly roof, cargo box power lift kit, etc); towing a trailer with 50 lb of tongue weight.

(A) Operator Weight:	200 lb
(B) HPX Diesel:	1473 lb
(C) Trailer Tongue Weight:	50 lb
(D) Cargo Load:	150 lb
(E) Attachments and/or Options:	220 lb

$$GVW = 2093 \text{ lb } (200 + 1473 + 50 + 150 + 220)$$

$$\text{Vehicle Load Capacity} = \text{GVWR } (3050) \text{ less } GVW (2093)$$

$$\text{Vehicle Load Capacity} = 957 \text{ lb}$$

The remaining vehicle load capacity of 957 lb can be used to haul additional passenger, cargo, trailer tongue and attachment weight.

QUO2005.00001BA-19-11SEP13

Operating

Loading the Cargo Box

⚠ CAUTION: The utility vehicle may become unstable if the cargo box is loaded incorrectly. Avoid loose and shifting loads or uneven loading of material.

- Do not load above height of load guard.
- Securely anchor all loads in cargo box.
- Do not load beyond maximum capacity.



MXAL42922—UN—15MAR13

See capacities in SPECIFICATIONS.

Reduce load by half when operating over rough, hilly, or steep terrain. Do not overload vehicle. Limit loads to those that can be safely controlled.

Reduce speed and exercise extreme caution when operating over rough, hilly, or steep terrain.

Securely anchor and evenly distribute loads in cargo box, when loading objects into vehicle. Shifting loads will affect stability.

Do not load above load guard (A).



MXAL42923—UN—15MAR13

Avoid concentrated loads at rear or side of cargo box to prevent vehicle from tipping over. Be sure load is evenly distributed.

Because there is a big difference in weight between dry and wet sand, the only way of getting true weight of the load you are carrying is by using a scale.

Printed weight is normally on bagged and other material.

JG81906.000070F-19-01APR13

Emptying Cargo Box

⚠ CAUTION: Raising a loaded cargo box changes the center of gravity. Keep vehicle a safe distance from the edge of ravine or drop-off when raising cargo box to empty.

A loaded cargo box can be very heavy. Do not attempt to manually raise a loaded cargo box. Unload cargo box before raising it by hand.



MXAL42924—UN—15MAR13

1. Back up vehicle to dump site.
2. Park the vehicle safely. (See Parking Safely in the SAFETY section.)
3. Open tailgate.

IMPORTANT: Stop emptying immediately if overload pressure relief valve opens. Lower cargo box completely and remove excess load by hand before dumping.

4. Raise cargo box to dump load.
5. Lower cargo box when empty.
6. Close tailgate. Do not drive vehicle with cargo box in raised position.

JG81906.0000710-19-01APR13

Towing Loads

⚠ CAUTION: Excessive towed load can cause loss of traction and loss of control on slopes. Stopping distance increases with speed and weight of towed load.

Do not tow a load that exceeds the maximum allowable towing load for this vehicle, as specified in this operator's manual.

Operating

- To provide adequate braking ability and traction, weight of towed load (trailer plus cargo) must never exceed the vehicle payload (operator plus passenger plus cargo box load).
- When operating over rough, hilly, or steep terrain and reducing cargo load by half, any towed load should also be reduced accordingly.
- Do not tow a load that exceeds towing capacity listed in SPECIFICATIONS.
- Do not exceed trailer tongue weight listed in SPECIFICATIONS. (The tongue load of a trailer should be approximately 10% of the total trailer weight.)
- Tow load at a speed slow enough to maintain control.

IMPORTANT: Extreme angles such as high railroad crossings can place high bending loads on hitch connection (A). Traversing terrain where the preceding conditions exist, use a ball type hitch.

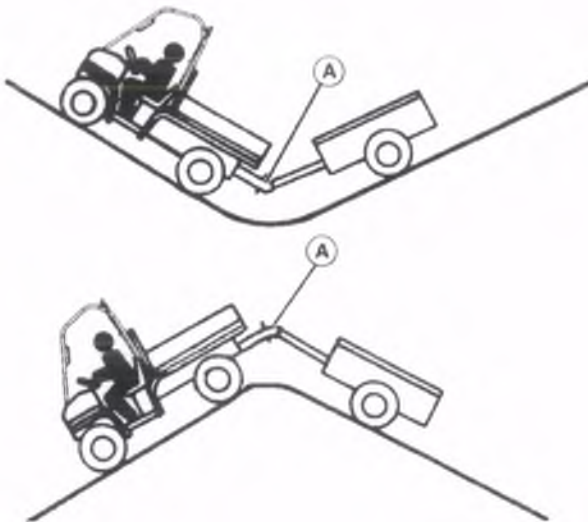

MXAL44186—UN—10APR13

- Always use approved hitch and hitch point provided for the utility vehicle. Do NOT modify the hitch or hitch point in any way.

Capacity Label



MXT007935—UN—18JUL13

Labels shown are for reference only. Confirm capacities on labels on your machine.

Your machine may have a hitch capacity label installed near the hitch area. The label indicates vertical and horizontal load capacities.

The vertical load capacity is the maximum down force which can be applied for safe operation. The horizontal load capacity is the total weight of what is being towed which must not be exceeded for safe operation.

MX00654.00000C1-19-26AUG13

Using Correct Tires and Inflation

CAUTION: Help prevent severe bodily injury or death, failure to observe these recommendations may result in loss of stability and operator control.

See tire descriptions and inflation pressures for load conditions in SPECIFICATIONS.

Tires

Use of John Deere approved original equipment or optional equipment is recommended. To ensure maximum machine performance and ride quality, do not mix size, type, or placement of tires. Failure to place tires per the guidelines could result in reduced machine performance, diminished traction and poor handling.

Inflation

CAUTION: Explosive separation of tire and rim parts is possible when they are serviced incorrectly:

- Do not attempt to mount a tire without the proper equipment and experience to perform the job.

Operating

- Do not inflate the tires above the recommended pressure.
- Do not weld or heat a wheel and tire assembly. Heat can cause an increase in air pressure resulting in an explosion. Welding can structurally weaken or deform the wheel.
- Do not stand in front or over the tire assembly when inflating. Use a clip-on chuck and extension hose long enough to allow you to stand to one side.

IMPORTANT: Over inflation may damage tires and diminish ride quality. Under inflation could cause wheel damage when riding over rough terrain.

An accurate low pressure gauge is available at your John Deere dealer.

JG81906.0000712-19-01APR13

Tire Chains

IMPORTANT: Loose tire chains can cause machine damage. Periodically check chain tightness and adjust as necessary.

Chains are available for all four wheels from your John Deere dealer.

JG81906.0000713-19-01APR13

Transporting Vehicle

Towing the Machine

IMPORTANT: Avoid Damage! Never tow the vehicle above 40 km/h (25 mph). Towing a vehicle at speeds above 40 km/h (25 mph) can result in transaxle damage.

To avoid damage, haul the vehicle in an enclosed trailer. If an open trailer must be used, haul on a heavy-duty trailer or on a full-size truck. Be cautious and travel at reduced speeds.

Optional accessories, such as a windshield, must be removed to avoid sudden unintentional separation from the vehicle.

Never use a car type dolly with the front wheels on the dolly.

Unlock park brake and keep transaxle shift lever in neutral (N) position for towing.

Vehicle Tie Down Locations

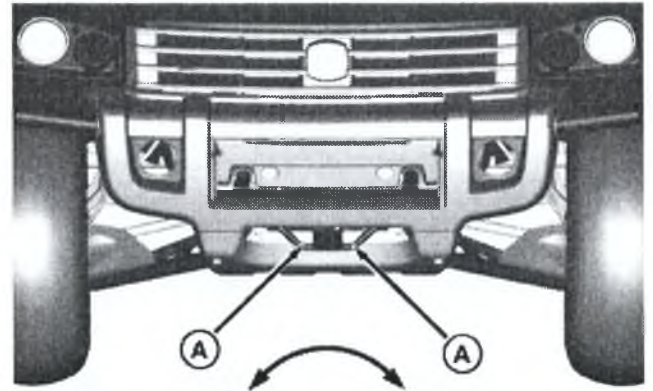

MXT020282—UN—14JUL17

- Fasten front of the machine through locations (A) on the front of the machine to trailer with a heavy-duty strap, chain, or cable. Strap must be directed down and outward from machine.

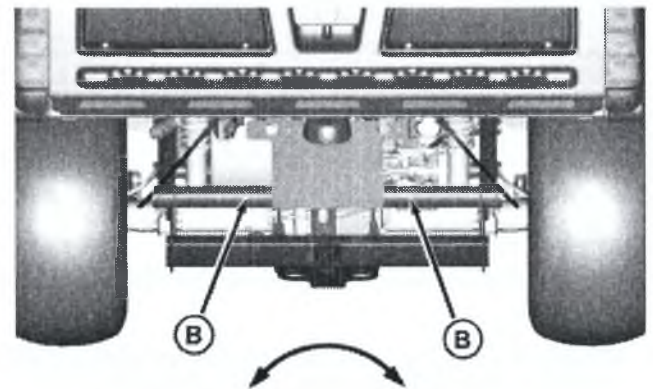

MXT020283—UN—14JUL17

- Fasten rear of the machine around locations (B) on the frame at rear of the machine to trailer with a heavy-duty strap, chain, or cable. Strap must be directed down and outward from machine.

Hauling the Machine

NOTE: Space limitations can vary from one truck manufacturer to another. Short bed trucks do not have the necessary length requirement to accommodate the machine.

Operating

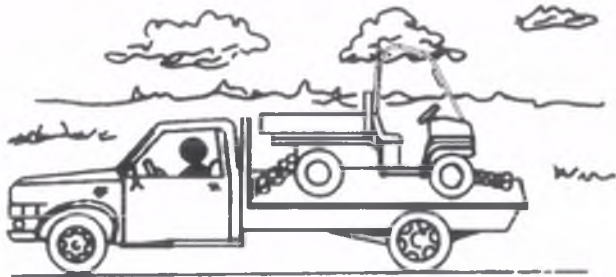
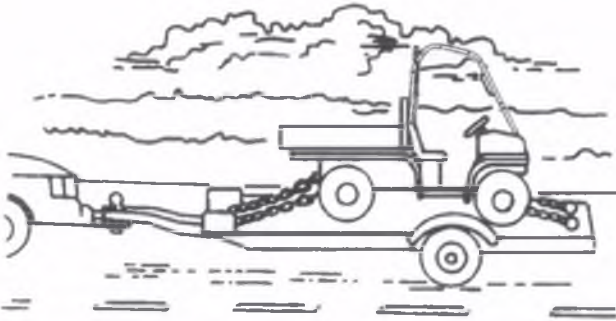

MXAL42928—UN—15MAR13

1. Back machine onto the trailer or truck.
2. Leave transaxle shift lever in forward or reverse gear.
3. Park the machine safely. (See Parking Safely in the SAFETY section.)
4. Fasten machine to trailer or truck with straps, chains, or cables.
5. Equip the trailer or truck with all the necessary lights and signs required by local, state, provincial, or federal laws.
6. Remove or secure optional attachments, if equipped.

OUMX068,0001327-19-14JUL17

Optional Attachments & Kits

Attachments and Kits

NOTE: All attachments and kits are not shown. Attachments and kits vary by machine model and may not be available in all regions. Specifications and design are subject to change without notice. See your John Deere dealer for availability in your region.

MX00654,00000E3-19-04SEP13

Cab Classification According to EN15695-1 (for Application of Crop Protection Chemicals and Liquid Fertilizer)

Cab classification according to EN 15695-1 provides information on the effectiveness of protection against harmful substances offered by the cab.

Categories 1 to 4 are used for classification and specified on a label inside the cab.

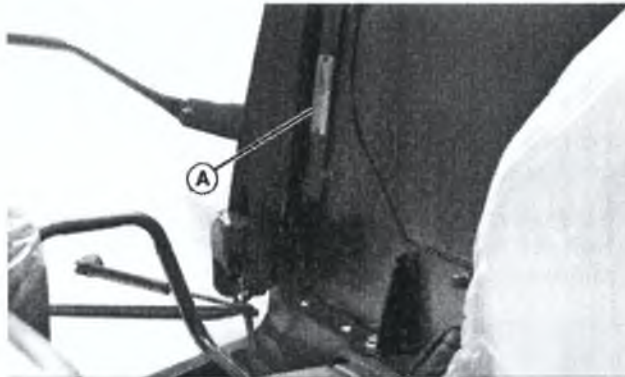

MXAL44190—UN—10APR13

Label is installed on cab behind passenger seat belt assembly.

Replace label (A) if missing or damaged. See your John Deere dealer.

A — Category 1 - The cab does not offer any protection against substances which are harmful to health.

B — Category 2 - The cab offers protection against solid airborne particles such as dust, but not against aerosols and vapors.

C — Category 3 - The cab offers protection against dust and aerosols (liquid airborne substances such as spray), but not against vapors.

D — Category 4 - The cab offers protection against dust, aerosols and vapors.

! CAUTION: Before working in an environment containing hazardous substances, i.e. when using pesticides, check whether the cab offers sufficient protection. Refer to the product data sheets of the spraying liquid manufacturer specifying the category required for the cab.

! CAUTION: In case of category 3 and 4 cabs, find out whether the installed filters have been checked according to EN 15695-2:2009 and whether they are suitable for the chemical being used (refer to the manufacturer's information) before working in an environment containing hazardous substances.

! CAUTION: The cab air filters must be serviced as specified. See Section "Service Miscellaneous" and "Service Intervals" in this Operator's Manual.

! CAUTION: Refer to product data sheets and product identification of the crop protection chemicals. These contain important information on how to avoid hazards.

The following requirements must be met to offer best protection:

1. All seals (on door, windows and roof) in good condition.
2. Doors, windows and roof closed.
3. Grommets for cables in the cab sealed properly.
4. Fan ON.
5. Cab air filters in good condition.

MP47322,00F4859-19-03APR13

Using Quick Clamps

Most optional attachments and kits use quick clamps to attach to the machine.

Using Clamps

1. Check and adjust the tightness of the clamps after the first 30 days of use.
2. If clamps are loose:

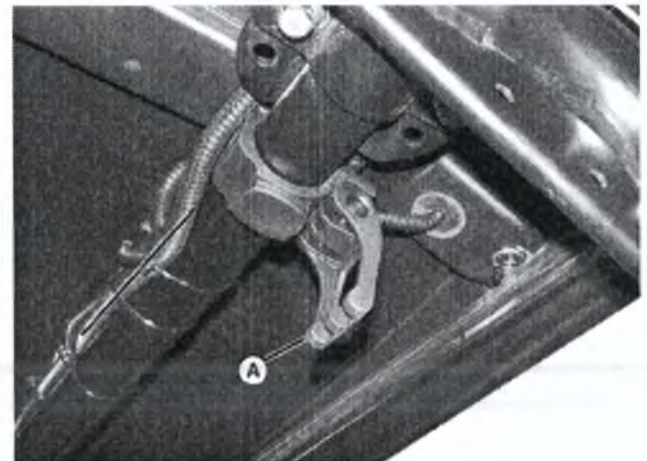

MXAL44191—UN—10APR13

- a. Open clamp arm lever (A).

Optional Attachments & Kits

- b. Increase tension by turning lever (A) one full turn clockwise. Repeat as needed.
 - c. Lock clamps.
3. If clamps are tight:
- a. Open clamp arm lever (A).
 - b. Decrease tension by turning lever (A) one full turn counter-clockwise. Repeat as needed.
 - c. Lock all clamps.

MP47322.00F485A-19-12APR13

⚠ CAUTION: Halogen light bulb contains gas under pressure. The bulb may shatter if the glass is scratched or dropped. Wear eye protection and handle bulb with care when replacing.

IMPORTANT: Do not touch glass portion of new bulb with bare skin. Contact with oils or dirt will reduce bulb life. Handle bulb by the base or with a clean cloth or gloves.

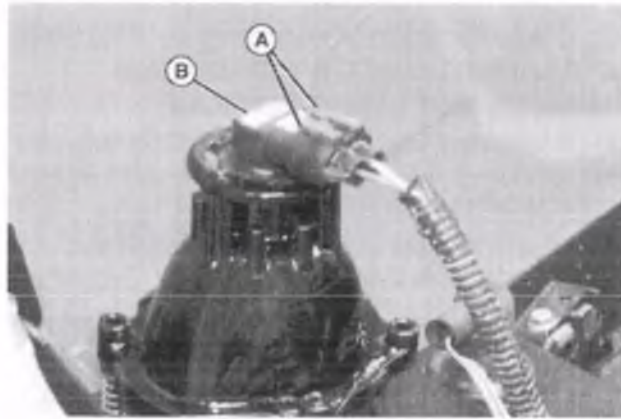

MXAL44194—UN—10APR13

3. Lift tabs (A) and remove wire harness connector from lamp socket.
4. Rotate lamp socket (B) 1/8 turn counterclockwise. Remove lamp and socket assembly from housing and discard.

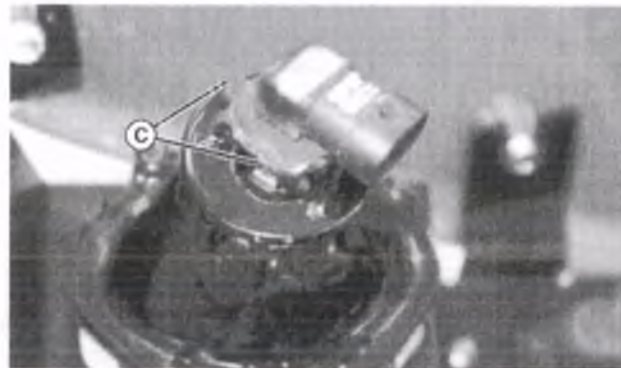

MXAL44195—UN—10APR13

5. To install new headlight, align lamp socket tabs (C) to housing slots, and rotate 1/8 turn clockwise to lock in place.
6. Connect wiring connector to new bulb/socket assembly.
7. Test headlight function.

Light Kits

Adjusting Lights

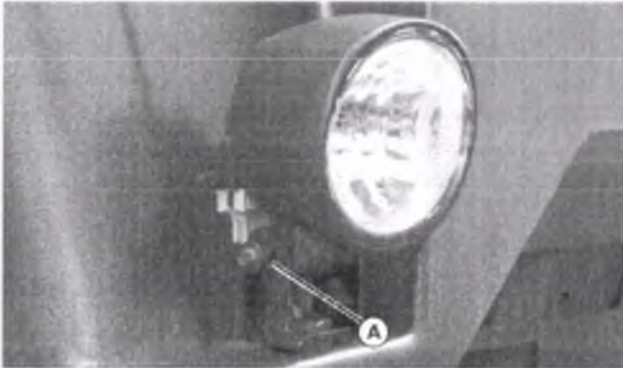

MXAL44192—UN—10APR13

- Mid-Range Lights: Loosen locknut (A) on bolt and direct light where needed. Tighten locknut to secure in position.



MXAL44193—UN—10APR13

- Hella Lights: Loosen bolt (A) on light and direct light where needed. Tighten bolt to secure in position.

Replacing Bulbs (Mid-Range Lights)

1. Park the machine safely. (See Parking Safely in SAFETY.)
2. Open the hood.

Optional Attachments & Kits

Replacing Bulbs (Hella HD Lights)



MXAL44196—UN—10APR13

1. Remove four hex head screws (A) and remove outer ring (B).

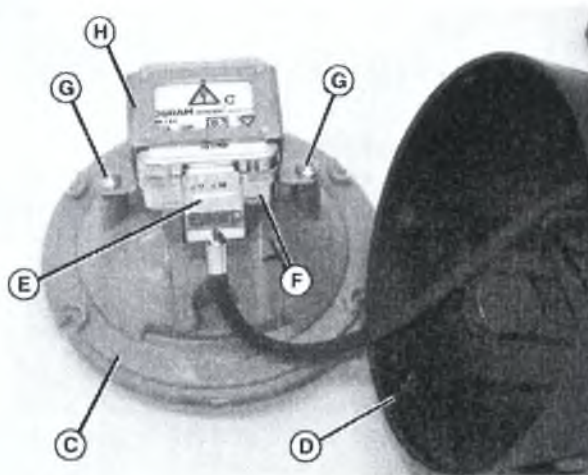

MXAL44197—UN—10APR13

2. Carefully remove assembly (C) from housing (D).
3. Disconnect wiring connector (E) from bulb assembly (F).
4. Remove two hex head screws (G) and retainer (H).
5. Remove bulb assembly from housing and replace.
6. Install new headlight lens assembly, and assemble components reverse order of removal.

Replacing Bulbs (Hella Halogen Lights)

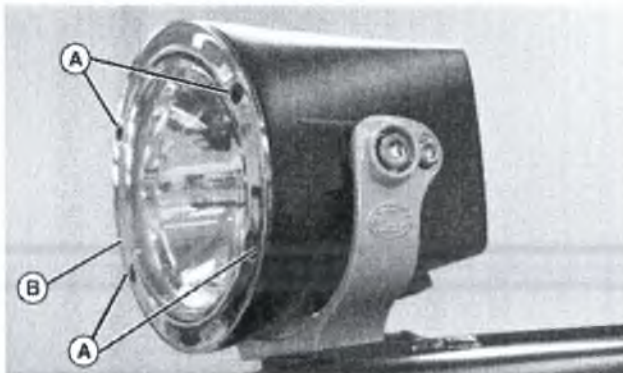

MXAL44198—UN—10APR13

1. Remove four hex head screws (A) and remove outer ring (B).

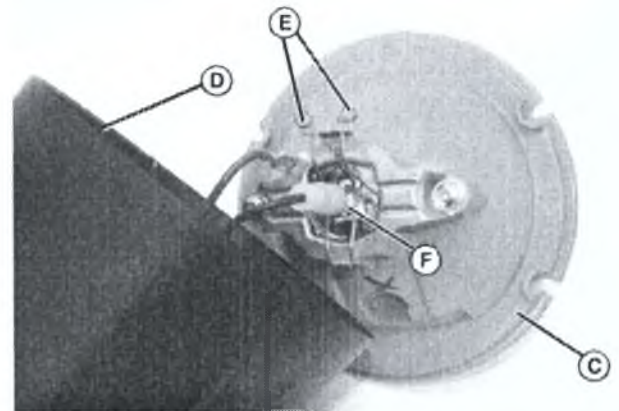

MXAL44199—UN—10APR13

2. Carefully remove assembly (C) from housing (D).
3. Press wire clips (E) together and remove bulb assembly (F).

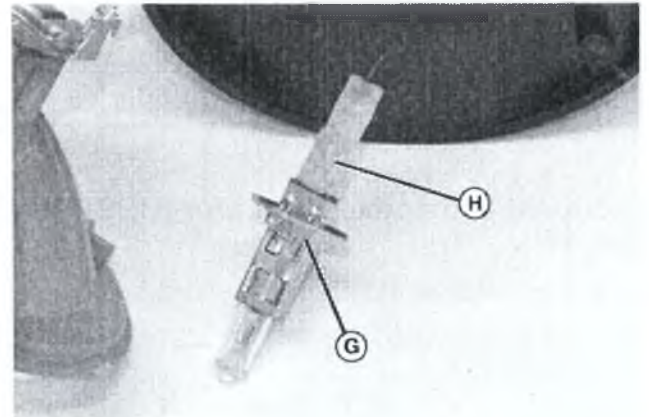

MXAL44200—UN—10APR13

4. Disconnect halogen bulb (G) from wiring harness connector (H) and replace.
5. Install new headlight lens assembly, and assemble components reverse order of removal.

MP47322.00F485B-19-03APR13

Backup Alarm

Periodically Check Alarm Function

1. Start machine.
2. Move transmission shift lever into Reverse gear and listen for alarm.
3. Contact your John Deere dealer if alarm does not function properly.

MP47322.00F485C-19-03APR13

Optional Attachments & Kits

Cab Heater

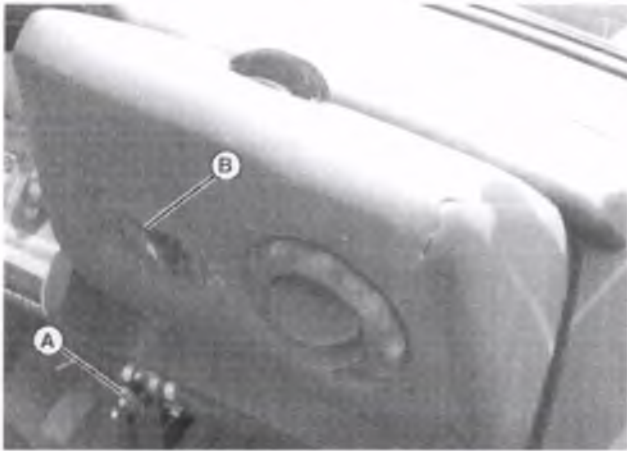

MXAL44201—UN—10APR13

1. Turn valve (A) to red arrow position to open for heat.
2. Push right side of switch (B) to first position for low fan speed or second position for high fan speed.
3. Push left side of switch fully down to turn fan off.
4. Turn valve to blue arrow position to close valve.

MP47322.00F485D-19-03APR13

Front Receiver Hitch

Using Hitch

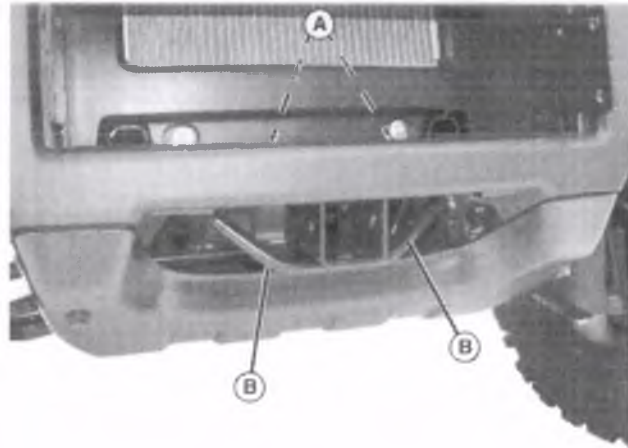

MXAL44203—UN—10APR13

1. Mount front accessories into holes (A) in front receiver hitch.
2. Use rings (B) as needed.

MP47322.00F485F-19-03APR13

Occupant Protective Structure (OPS) Rear Screen

Adjusting Headrest Position

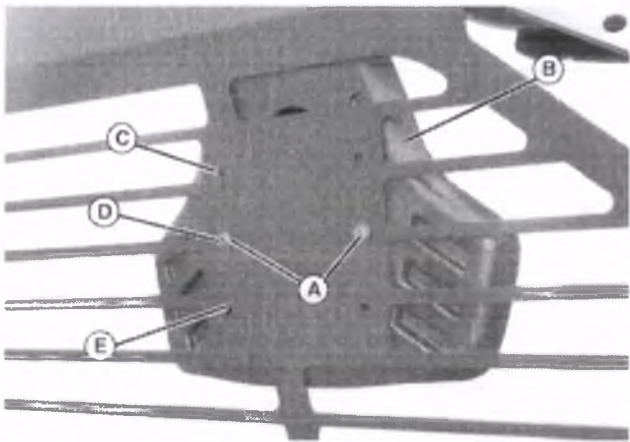

MXAL44202—UN—10APR13

Headrest shown in center position.

1. Remove two screws (A) and move each headrest (B) to either top (C), center (D) or bottom (E) position. Secure with two screws.

MP47322.00F485E-19-03APR13

Using a Trailer

Follow all trailer manufacturers instructions for safe operation.

Follow all instructions in this Operators Manual for attaching optional equipment and towing loads safely.

MP47322.00F4860-19-23JUN15

Service Intervals

Servicing Your Machine

IMPORTANT: Operating in extreme conditions may require more frequent service intervals:

- Engine components may become dirty or plugged when operating in extreme heat, dust or other severe conditions.
- Engine oil can degrade if machine is operated constantly at slow or low engine speeds or for frequent short periods of time.

Please use the following timetables to perform routine maintenance on your machine.

JG81906.0000718-19-01APR13

Break In

After First 8 Hours:

- Check and tighten wheel bolts to correct torque.
- Check brake fluid level.

After First 50 Hours:

- Change engine oil and filter.

OUO2005.00001BD-19-12SEP13

Every 50 Hours

- Lubricate drive line (three locations).
- Check 4WD front differential oil level.
- Check transaxle oil level.
- Check brake fluid level and brake line connections.
- Inspect driveline CV boots for tears and punctures.
- Inspect park brake for proper function. (See your John Deere dealer for any adjustment needed.)

OUMX068.0000C40-19-22JUN15

Every 200 Hours or Annually (whichever comes first)

- Change engine oil and filter.
- Change fuel filter.
- Check spark arrestor.
- Check air restriction indicator.
- Inspect alternator belt.
- Check air cleaner dust unloading valve.
- Clean radiator.
- Check drive belt condition.
- Check driven clutch wear buttons.
- Check brake pad wear.
- Clean primary drive clutch.

- Inspect battery. Clean if necessary.
- Check and tighten wheel bolts to correct torque.
- Check toe-in.
- Check and tighten all hardware.

OUMX068.0000C41-19-22JUN15

Every 400 Hours or 24 Months (whichever comes first)

- Test or replace radiator cap. (See your John Deere dealer for this service.)
- Inspect suspension bushings for play. (See your John Deere dealer for this service.)
- Inspect wheel bearings for play.

OUMX068.0000C42-19-22JUN15

Every 800 Hours or 24 Months (whichever comes first)

- Change transaxle oil.
- Change 4WD front differential oil.
- Replace drive belt.

JG81906.000071F-19-01APR13

Every 1000 Hours or 24 Months

- Change engine coolant.
- Flush and refill brake fluid. (See your John Deere dealer for this service.)
- Inspect shocks and struts for leaks.

OUMX068.0000C43-19-22JUN15

Every 1000 Hours

- Adjust engine valve clearance. (See your John Deere dealer for this service.)

OUO2005.00001C2-19-12SEP13

Service Lubrication

Grease

IMPORTANT: Avoid Damage! Use recommended John Deere greases to avoid component failure and premature wear.

The following grease is recommended for service:

- John Deere Multi-Purpose HD Lithium Complex Grease
- Grease-Gard™ Premium Plus

Not all grease types are compatible; John Deere does not recommend mixing greases. If using any product other than the recommended grease in service, purge any remaining grease from the system prior to application. If this is not practical, grease twice as often until all old grease is purged from the system.

OUMX068,0000642-19-27AUG14

2. Lubricate two grease fittings (A) on the drive line with one or two shots of grease.

MX10673,0000034-19-25JUL17

Lubricating Drive Line

1. Park the machine safely. (See Parking Safely in the SAFETY section.)

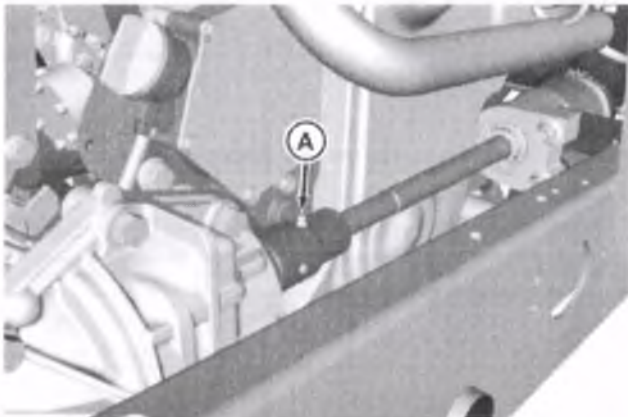

MXT020309—UN—25JUL17

View from right rear of machine - on rear driveshaft.

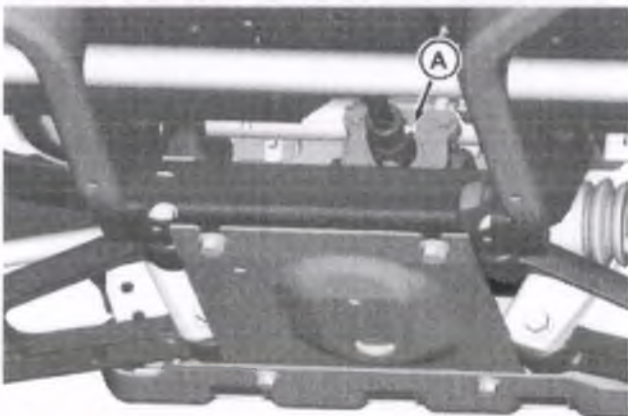

MXT020310—UN—25JUL17

Service Engine

Avoid Fumes

⚠ CAUTION: Engine exhaust fumes contain carbon monoxide and can cause serious illness or death.

- Move the machine to an outside area before running the engine.
- Do not run an engine in an enclosed area without adequate ventilation.
- Connect a pipe extension to the engine exhaust pipe to direct the exhaust fumes out of the area.
- Allow fresh outside air into the work area to clear the exhaust fumes out.

JG81906,0000723-19-01APR13

Engine Oil

Use oil viscosity based on the expected air temperature range during the period between oil changes.

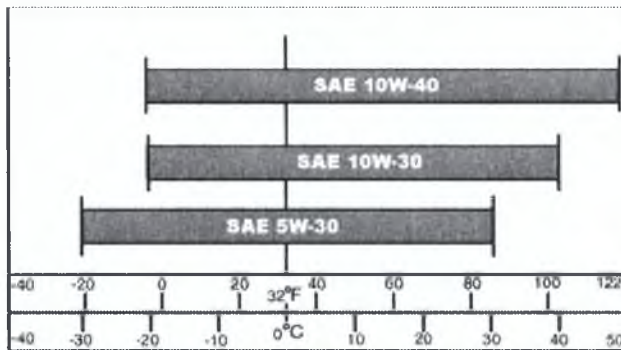

MXAL44546—UN—28MAR13

The following John Deere oils are preferred:

- Torq-Gard Supreme™
- PLUS- 50™

Other oils may be used if above John Deere oils are not available, provided they meet the following specification:

- API Service Classification CD or higher

MX00654,0000104-19-06SEP13

Checking Engine Oil Level

IMPORTANT: Failure to check the oil level regularly could lead to serious engine problems if oil level is out of the operating range:

- Check oil level before operating.
- Check oil level when the engine is cold and not running.
- Keep oil level between the dipstick marks.
- Shut off engine before adding oil.

1. Park the vehicle safely. (See Parking Safely in the SAFETY section.)
2. Raise and secure cargo box.



MXT008892—UN—10SEP13

3. Remove dipstick (A) and wipe it clean.
4. Install dipstick.
5. Remove dipstick.
6. Check oil level:
 - Oil level must be between fill marks on dipstick.
 - If oil level is low, add oil to bring oil level no higher than upper mark on dipstick.
 - If oil level is above upper mark, drain to proper level. Determine cause of this condition and correct.
7. Install dipstick.
8. Lower the cargo box.

OU02005,00001D1-19-12SEP13

Changing Engine Oil and Filter

IMPORTANT: Change the oil more often if the vehicle is used in extreme conditions:

- Extremely dusty conditions.
- Frequent slow or low-speed operation.
- Frequent short trips.

1. Run engine to warm the oil.
2. Park the vehicle safely. (See Parking Safely in the SAFETY section.)
3. Raise and secure cargo box.
4. Place drain pan under engine drain valve.

Service Engine



MXT008893—UN—10SEP13

5. Remove drain plug (A). Allow oil to drain completely.

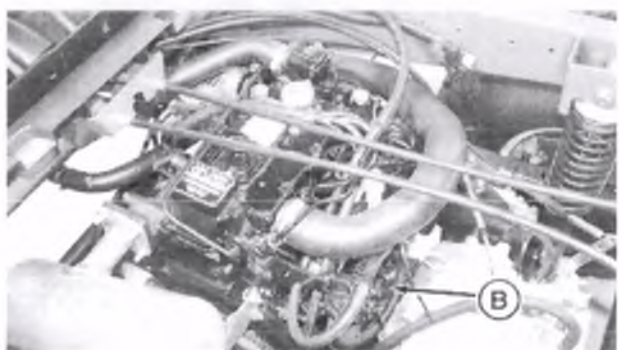

MXT008894—UN—10SEP13

6. Remove and discard oil filter (B) on transaxle side of engine. Wipe off filter base on engine.
7. Put a light coat of clean engine oil on gasket of new oil filter.
8. Install new filter until rubber gasket contacts filter base. Tighten filter an additional one-half turn.
9. Install drain plug.

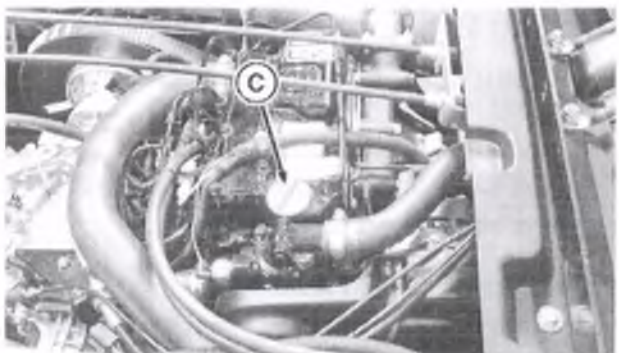

MXT008895—UN—10SEP13

10. Remove oil fill cap (C) from filler opening.

IMPORTANT: Avoid damage! Do not overfill crankcase with oil. Oil capacities given are with engine and crankcase completely dry. Some oil will remain in engine after draining.

11. Add oil no higher than upper mark on dipstick. Do not overfill.
12. Install oil fill cap.

13. Start and run engine at idle to check for leaks. Stop engine. Fix any leaks before operating.
14. Stop engine.
15. Check oil level; add oil if necessary.
16. Lower the cargo box.

OUO2005.00001D2-19-17SEP13

Cleaning Dust Unloading Valve

IMPORTANT: Do not operate engine without air cleaner element and rubber dust unloading valve installed.

1. Park the vehicle safely. (See Parking Safely in the SAFETY section.)
2. Allow engine to cool.
3. Access the engine compartment.

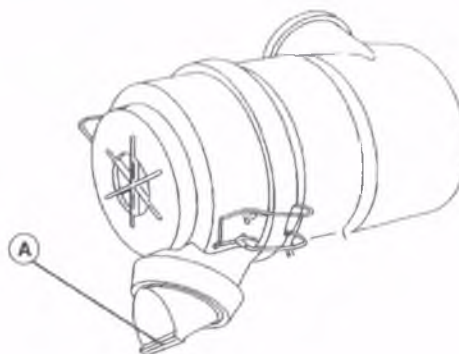

MXAL42935—UN—15MAR13

4. Squeeze dust unloading valve (A) to clean. Remove and replace if damaged.

JG81906.0000727-19-01APR13

Checking Air Restriction Indicator

IMPORTANT: Avoid damage! Never check air cleaner until restriction indicator is red or at 6.2 kPa (25 in. H₂O) vacuum. This keeps contamination of the intake system to a minimum.

Check air restriction indicator more frequently if operating in dusty conditions.

1. Lock park brake.
2. Place transmission in N (neutral).
3. Start the engine.

Service Engine

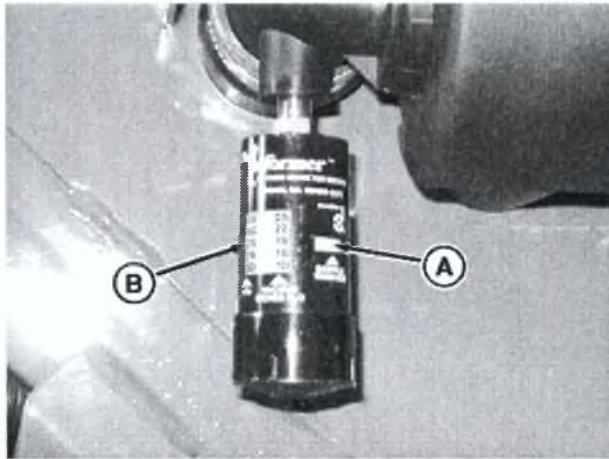

MXT008896—UN—10SEP13

4. Check the color at sight window (A) and vacuum reading at scale (B).
5. Stop the engine and wait for all moving parts to stop.
6. Service air cleaner element if sight window shows red or reading is at 6.2 kPa (25 in. H₂O) vacuum.

OUO2005.00001D4-19-12SEP13

Servicing Air Cleaner Element

IMPORTANT: Avoid damage! Dirt and debris can enter engine when air cleaner canister is opened. Do not open canister unless required for scheduled service, keeping contamination of the intake system to a minimum.

Check filter element more frequently if operating in dusty conditions.

1. Park the machine safely. (See Parking Safely in the SAFETY section.)
2. Allow engine to cool.

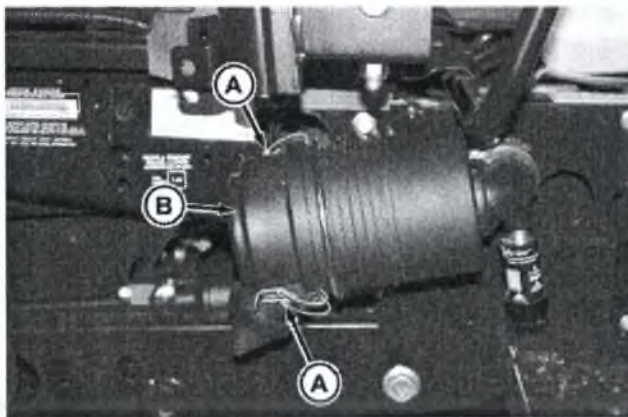

MXT020311—UN—26JUL17

3. Release latches (A) and remove air cleaner cover (B).

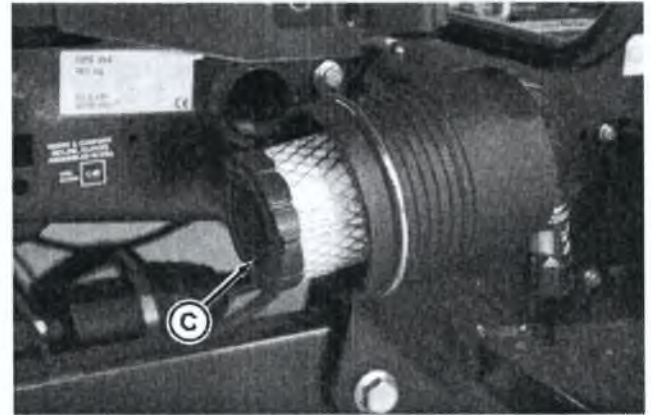

MXT020312—UN—26JUL17

4. Remove and discard filter element (C). Replace with a new filter element.
5. Install air cleaner cover with rubber dust unloading valve pointing downward. Check instruction molded into canister cover for proper installation.
6. Hook the canister cover latches.

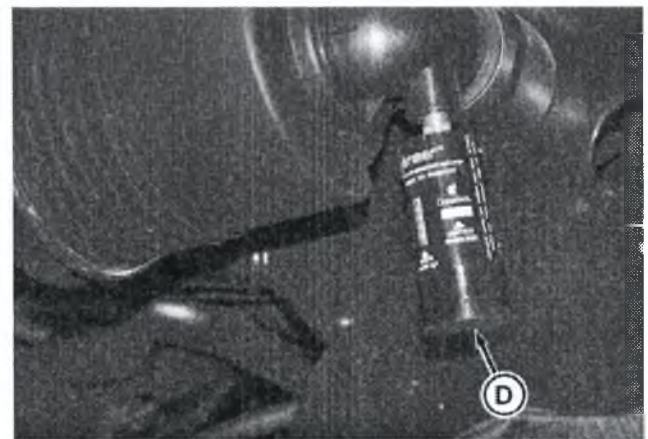

MXT020313—UN—26JUL17

7. Press reset button at the end of the air filter restriction indicator (D).
8. Start engine and run at slow idle.
9. Check reading on the air filter restriction indicator with engine running.
10. Shut off engine and wait for all moving parts to stop.

IMPORTANT: Avoid damage! Do not service secondary air filter element unless air filter restriction indicator rises above 2.5 kPa (10 in. of H₂O) after primary element was replaced.

11. If air filter restriction indicator went above 2.5 kPa (10 in. of H₂O), change secondary air filter element:
 - a. Remove air cleaner cover.
 - b. Remove primary air filter element.

Service Engine

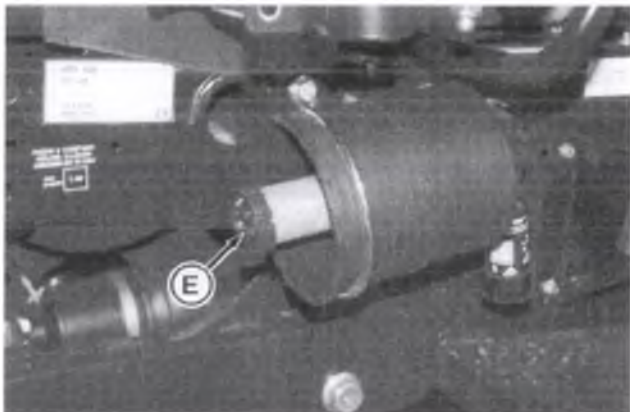

MXT020314—UN—26JUL17

- c. Pull secondary air filter element (E) from canister. Discard the filter element.
- d. Install new secondary air filter element.
- e. Install primary air filter element.
- f. Install canister cover.
- g. Push reset button on the air filter restriction indicator.

MX10673.0000032-19-26JUL17

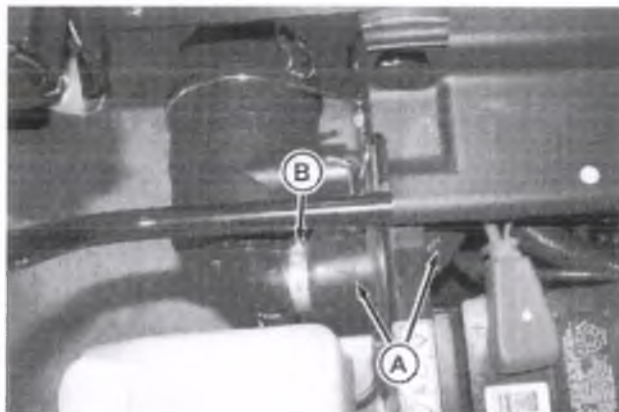

MXT020315—UN—26JUL17

4. Check intake hose (A) for damage or cracking. Replace if necessary.
5. Check and tighten hose clamps (B) as needed.
6. Lower the cargo box.
7. Lower passenger seat.

MX10673.0000033-19-26JUL17

Checking Air Intake, Hoses and Clamps

1. Park the machine safely. (See Parking Safely in the SAFETY section.)
2. Raise passenger seat.
3. Raise and secure cargo box.

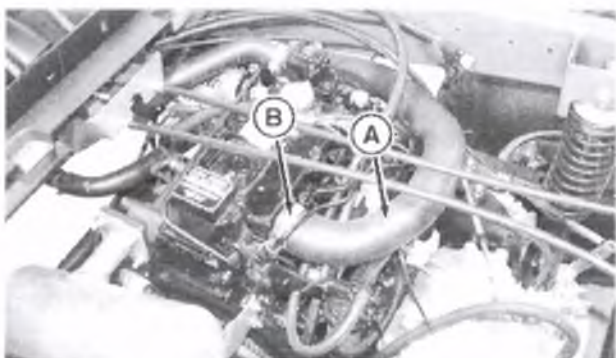

MXT008901—UN—10SEP13

Servicing Sediment Bowl

⚠ CAUTION: Avoid injury! Fuel vapors are explosive and flammable:

- Do not smoke while handling fuel.
- Keep fuel away from flames or sparks.
- Shut off engine before servicing.
- Cool engine before servicing.
- Work in a well-ventilated area.
- Clean up spilled fuel immediately.

1. Park the machine safely. (See Parking Safely in the SAFETY section.)
2. Allow engine to cool.
3. Raise and secure cargo box.

Checking

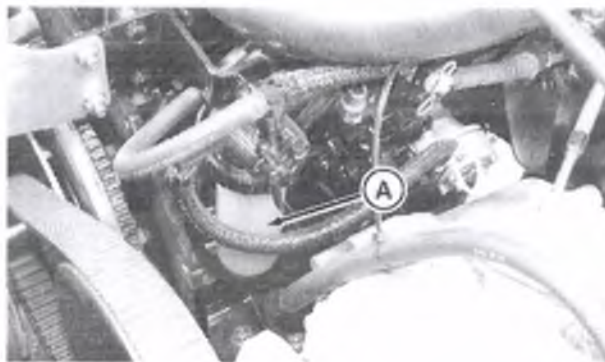

MXT008903—UN—10SEP13

1. Check for water in sediment bowl (A):
 - Red ring will float on top of the water.

Service Engine

2. If necessary, clean bowl and replace filter.

Cleaning

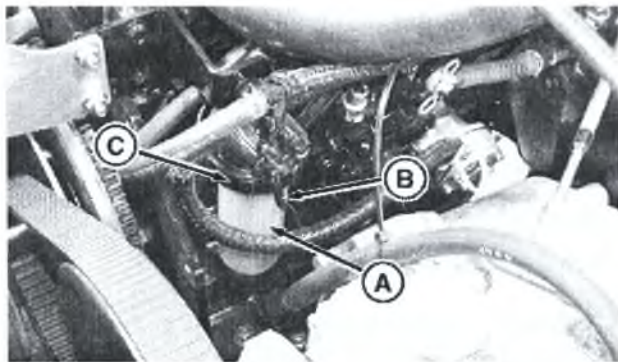

MXT008904—UN—10SEP13

1. Close fuel shut-off valve (B).
2. Turn collar (C) to remove bowl (A).
3. Remove filter from inside bowl. Discard filter.

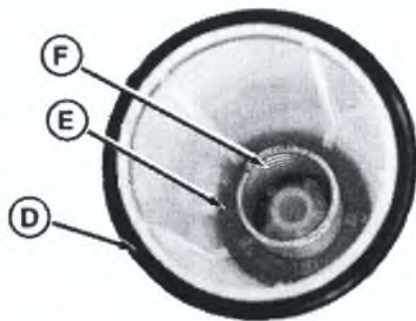

MXT008905—UN—10SEP13

4. Remove and retain O-ring (D), float ring (E), and spring (F) from bowl. Clean bowl and allow drying.
5. Install O-ring, float ring, spring, and new filter into bowl.
6. Install bowl to filter head and tighten collar to secure.
7. Open fuel shut-off valve.
8. Lower the cargo box.
9. Bleed fuel system.

OUO2005,00001D6-19-12SEP13

Bleeding Fuel System

IMPORTANT: Avoid damage! Modification or alteration of injection pump, pump timing, or fuel injectors in a manner not recommended by the manufacturers will terminate the warranty obligation to the purchaser.

DO NOT attempt to service injection pump or fuel injectors yourself. Special training and special tools are required. See your John Deere dealer.

Bleed air from fuel system:

- After you, service fuel system.
 - If you run out of fuel.
1. Make sure there is fuel in the tank.
 2. Open fuel shut-off valve on filter.

NOTE: If fuel filter has been cleaned or changed, fuel will be heard immediately returning to tank when primer lever is operated. Continue operating lever until you can hear the return flow stop and then start again.

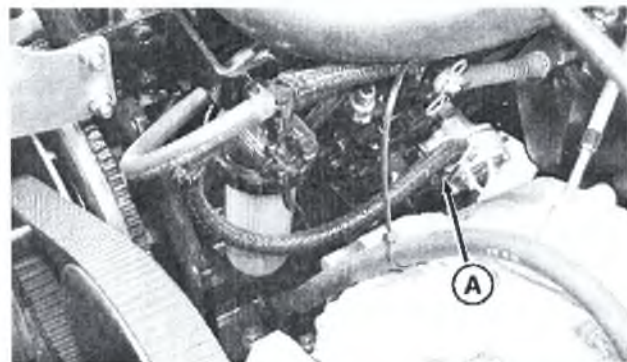

MXT008906—UN—10SEP13

3. Access fuel pump primer lever (A) through opening at rear of vehicle. Move lever up and down. Continue operating lever until:
 - Fuel filter bowl is full of fuel.
 - You can hear fuel returning to tank through return hose.

OUO2005,00001D7-19-12SEP13

Servicing Fuel Injection Pump

IMPORTANT: Fuel injection pump is calibrated by the engine manufacturer and should not be adjusted.

Do not clean a warm fuel injection pump with steam or water.

Changing injection pump in any way not approved by the manufacturer will end warranty. See your John Deere warranty on this machine.

Do not service injection pump. See your John Deere dealer for service.

If engine is difficult to start, lacks power, or runs rough, check the TROUBLESHOOTING section of this manual. If your engine is still not performing correctly, contact your John Deere dealer.

MX00654,000010C-19-06SEP13

Service Engine

Servicing Fuel Injection Nozzles

IMPORTANT: Do not service or remove fuel injection nozzles. Service life of injection nozzles may be shortened by overheating, improper operation, poor fuel quality, or excessive idling.

Incorrectly functioning, or dirty injection nozzles, will cause the engine to run poorly. See your John Deere dealer for service.

MX00654 000010D-19-06SEP13

Cleaning Engine Compartment

CAUTION: Touching hot surfaces can burn skin. The engine, components, and fluids will be hot if the engine has been running. Allow the engine to cool before servicing or working near the engine and components.

1. Park the vehicle safely. (See Parking Safely in the SAFETY section.)
2. Raise and secure cargo box.

IMPORTANT: Do not spray water on a hot engine or transaxle. Damage may occur to cast aluminum parts. Allow engine to cool before servicing.

3. Remove any debris in engine compartment.
4. Check and remove any obstructions around the control cables and linkages.

JG81906 000072D-19-01APR13

Cleaning Grille

IMPORTANT: Grille screen must be clean to prevent engine from overheating and to allow adequate air intake.

1. Check grille screen for dirt, grass clippings and debris.
2. Clean grille screen by washing or with a brush or cloth.

JG81906 000072E-19-01APR13

Cleaning Radiator Cooling Fins

CAUTION: Avoid injury! Compressed air can cause debris to fly a long distance.

- Clear work area of bystanders.
- Wear eye protection when using compressed air for cleaning purposes.

- Reduce compressed air pressure to 210 kPa (30 psi).

IMPORTANT: Avoid damage! Cooling fins must be clean to prevent engine from overheating and to allow adequate air intake.

1. Park the vehicle safely. (See Parking Safely in the SAFETY section.)
2. Open hood.
3. Remove storage tray.

IMPORTANT: Avoid damage! High-pressure water or air can damage cooling fins or other engine components. Use water from a hose or reduce compressed air pressure to 210 kPa (30 psi).

Turn engine off before cleaning radiator screen and fins.



MXT014778—UN—23JUN15

4. Remove all dirt and debris from radiator fins and fan shroud (A) using compressed air or water. Flow of compressed air or water must be from back to front.
5. Install storage tray.
6. Close hood.

OUMX068 0000C49-19-26JUL17

Checking Coolant Level

1. Park the vehicle safely. (See Parking Safely in the SAFETY section.)
2. Allow engine to cool.
3. Open hood.

Service Engine

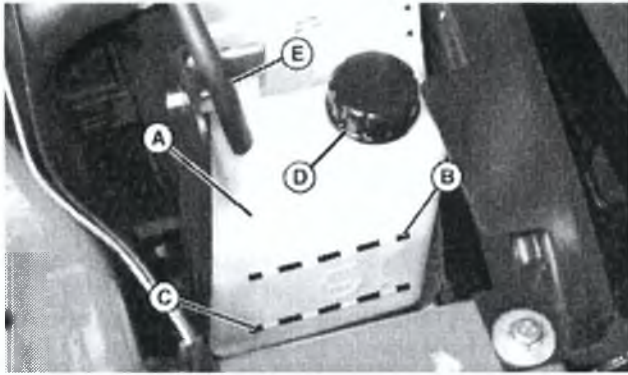

MXAL42943—UN—15MAR13

4. Check recovery tank (A) coolant level:
 - If engine is warm, coolant level should be between the FULL line (B) and the LOW line (C).
 - If engine is cold, coolant level should be at the LOW line (C) on the recovery tank.
5. Remove recovery tank cap (D) if necessary to add coolant.
6. Add coolant mixture to recovery tank.

IMPORTANT: Installing suction hose incorrectly will not allow coolant into the coolant system. Do not allow bottom of hose to touch bottom of bottle or bend upwards out of coolant.

7. Install and tighten recovery tank cap.
8. Close hood.

JG81906,0000730-19-01APR13

Service Cooling System Safely



MXAL42944—UN—28MAR13

⚠ CAUTION: The radiator will be hot and can burn skin. Built-up pressure may cause explosive release of coolant when the radiator cap is removed:

- Shut off the engine and allow to cool.
- Do not remove the cap unless the radiator and the engine are cool enough to touch with bare hands.

- Slowly loosen the cap to the first stop to release all pressure. Then remove the cap.

JG81906,0000731-19-01APR13

Servicing Cooling System

IMPORTANT: Avoid damage! Follow all service procedures exactly. If not equipped to perform this work, see your John Deere dealer for service.

Prepare Vehicle

1. Park the vehicle safely. (See Parking Safely in the SAFETY section.)
2. Raise cargo box.
3. Tip seats forward.
4. Open hood.
5. Remove storage tray.
6. When the coolant system service is completed:
 - Install storage tray.
 - Close hood.
 - Tip seats back.
 - Lower cargo box.

Draining Cooling System

1. Make sure engine has cooled completely.
2. Place drain pan under engine.

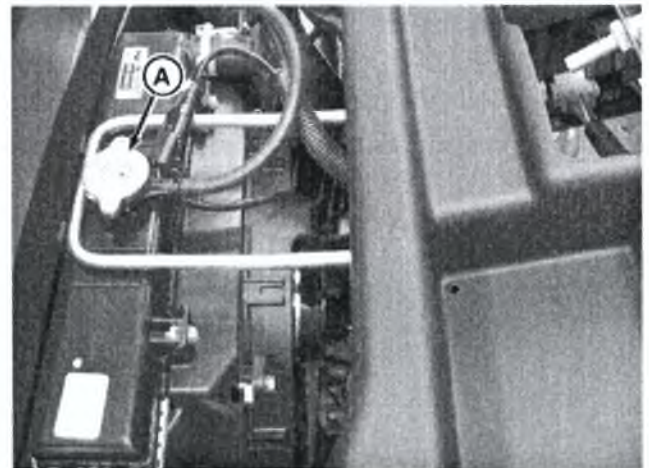

MXT014779—UN—23JUN15

3. Slowly open radiator cap (A) to the first stop to release all pressure.
4. Remove cap after all pressure is released.

Service Engine

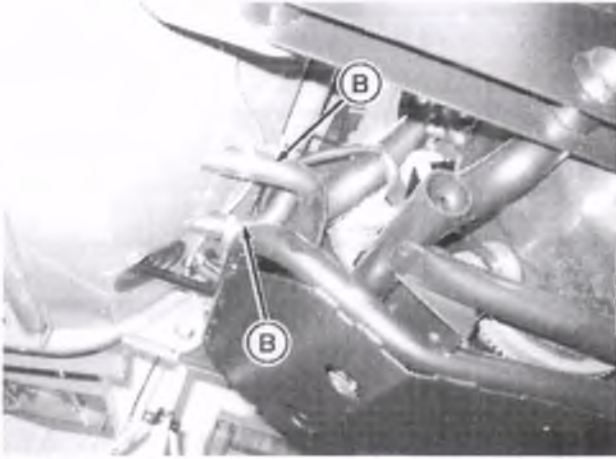

MXT008908—UN—10SEP13

5. Disconnect radiator hoses (B) from intermediate tubes.
6. Route radiator hoses over the drain pan and allow coolant to drain into drain pan.

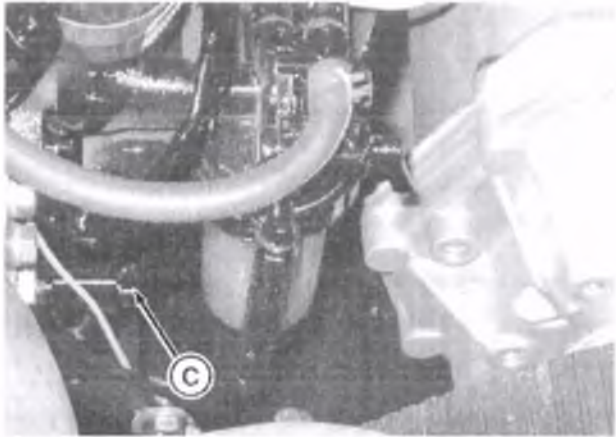

MXT008909—UN—10SEP13

7. Loosen engine block drain (C) near engine oil filter. Allow coolant to drain into a container.
8. After all coolant has drained, connect radiator hoses and tighten the engine block drain screw.



MXAL42948—UN—15MAR13

9. Remove overflow hose (D) from recovery tank.
10. Remove the screw (E) and lift recovery tank out of machine.

11. Remove cap and empty recovery tank into drain pan.
12. Check condition of all hoses. Replace as needed. Check all hose clamps and tighten as needed.
13. Install recovery tank in machine and secure with screw (E).

IMPORTANT: Avoid damage! Install overflow hose properly to ensure proper function of the cooling system. Position hose slightly above bottom of reservoir. Do not allow hose to contact bottom of reservoir or bend upwards out of the coolant.

14. Install overflow hose (D) and cap (F).
15. Fill and bleed cooling system.

Filling and Bleeding Cooling System

IMPORTANT: Avoid damage! Using incorrect coolant mixture can damage the radiator:

- Do not operate engine without coolant or with plain water.
- Use antifreeze approved for use in aluminum engines.
- Do not exceed a 50% antifreeze mixture for the coolant.
- Do not pour coolant or water into radiator when engine is hot.
- Do not add Stop Leak or other additives.

NOTE: John Deere Cool-Gard coolant is recommended when adding coolant to the cooling system. Follow the directions on the container for correct mixture ratio.

Cooling system capacity is approximately 5.0 L (5.2 qt.) including recovery tank.

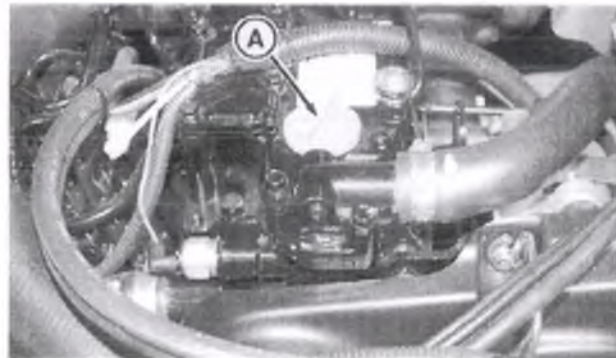

MXT008910—UN—10SEP13

1. Remove bleed screw (A) on the thermostat housing.
2. Remove radiator cap and add recommended coolant mixture to radiator until coolant runs out of bleed port.
3. Install and tighten bleed screw.

Service Engine

4. Add extra coolant mixture to radiator until coolant runs out of overflow port and into the recovery tank.
5. Install radiator cap.

IMPORTANT: Avoid damage! Installing suction hose incorrectly does not allow coolant into the coolant system. Do not allow bottom of hose to touch bottom of recovery tank or bend upwards out of coolant.

6. Remove recovery tank cap and add coolant mixture to recovery tank until it is approximately half full.
7. Install recovery tank cap.

IMPORTANT: Avoid damage! If coolant temperature indicator comes on while engine is running, stop engine and add more coolant mixture to radiator.

8. Start and run engine at medium speed until upper and lower radiator hoses have become warm (10—15 minutes). This time ensures that the thermostat has opened and coolant is circulating.
9. Allow engine to cool.
10. Loosen bleed screw and allow air to bubble out until air bubbles are no longer visible at bleed port. Tighten bleed screw completely.
11. Remove radiator cap and add recommended coolant mixture to radiator until coolant runs out of overflow port and into the recovery tank.
12. Install radiator cap.
13. Run engine until cooling fan starts, indicating the engine and coolant has reached operating temperature.
14. Stop engine and remove key.
15. Allow engine to cool and suction back any needed coolant from overflow recovery tank. Fill recovery tank to lower line, if necessary.

Flushing Cooling System

1. Drain cooling system.
2. Prepare a cooling system flushing solution using clean water and John Deere Cooling System Cleaner, John Deere Cooling System Quick Flush, or an equivalent.
3. Fill radiator completely with flushing solution. Install and tighten radiator cap.
4. Start and run engine until it reaches operating temperature.
5. Stop engine.

⚠ CAUTION: Avoid injury! The radiator is hot and can burn skin. Built-up pressure can cause explosive release of coolant when the radiator cap is removed:

- Slowly loosen the cap to the first stop to release all pressure. Then remove the drain plug.
6. Turn radiator cap slowly to the stop to release system pressure. Remove radiator cap.
 7. Drain cooling system immediately into a container before rust and dirt settle:
 - Disconnect radiator hoses from engine.
 - Loosen engine block drain screws.
 8. After all solution has drained, connect radiator hoses and tighten engine block drain screws.
 9. Remove and clean recovery tank.
 10. Install the recovery tank.
 11. Fill cooling system with recommended coolant mixture.

OUMX068,0000C4A-19-23JUN15

Recommended Engine Coolant

IMPORTANT: Using incorrect coolant mixture can cause overheating and damage to the radiator and engine:

- Do not operate engine with plain water.
- Do not exceed a 50% mixture of coolant and water.
- Aluminum engine blocks and radiators require approved ethylene-glycol based coolant.

The engine cooling system is filled to provide year-round protection against corrosion and cylinder liner pitting, and winter freeze protection to -37 degrees C (-34 degrees F). If protection at lower temperatures is required, consult your John Deere dealer for recommendations.

The following coolants are preferred:

- John Deere COOL-GARD™ II Premix
- John Deere COOL-GARD™ Premix
- John Deere COOL-GARD™ PG Premix

John Deere COOL-GARD™ II Premix and John Deere COOL-GARD™ Premix are available in a concentration of 50% propylene glycol.

John Deere COOL-GARD™ PG Premix is available in a concentration of 55% propylene glycol.

Additional recommended coolants:

Service Engine

- John Deere COOL-GARD™ II Concentrate in a 40% to 60% mixture of concentrate with water.
- John Deere COOL-GARD™ Concentrate in a 40% to 60% mixture of concentrate with water.

If the recommended coolants are unavailable, use an ethylene glycol or propylene glycol base coolant that meets the following specification:

- ASTM D3306 prediluted (50%) coolant.
- ASTM D3306 coolant concentrate in a 40% to 60% mixture of concentrate with water.

Check container label before using to be sure it has the appropriate specifications for your machine. Use coolant with conditioner or add conditioner to coolant before using.

Water Quality

- Water quality is important to the performance of the cooling system. Distilled, deionized, or demineralized water is recommended with ethylene glycol base engine coolant concentrate.

JG81906.0000733-19-05APR13

Checking Radiator Hoses and Clamps

1. Park the vehicle safely. (See Parking Safely in the SAFETY section.)
2. Raise cargo box.
3. Tip seats forward.
4. Open hood.
5. Remove storage tray.

NOTE: Visually inspect hoses for cracks and wear. Squeeze hoses to check for deterioration. Hoses must not be hard and brittle, nor soft or swollen.

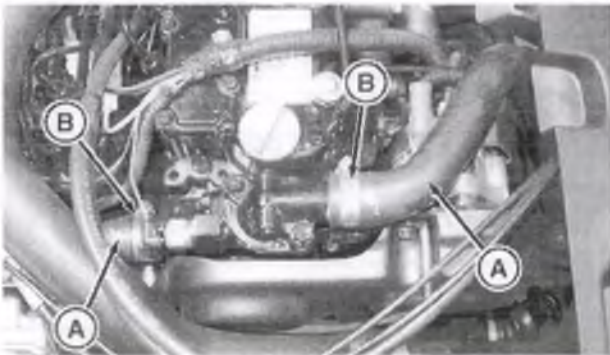

MXT008911—UN—10SEP13

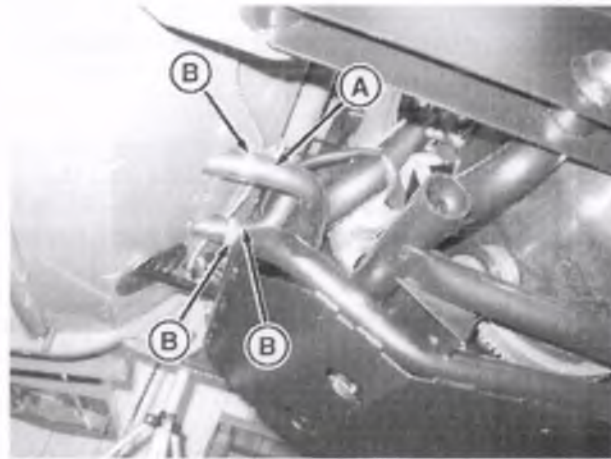

MXT008912—UN—10SEP13

6. Check radiator hoses (A) between intermediate tubes and engine for damage or cracking. Replace if necessary.
7. Check hose clamps (B) and tighten or replace as needed.



MXT014760—UN—23JUN15

8. Check radiator hose (C) between intermediate tubes and radiator for damage or cracking. Replace if necessary.
9. Check hose clamps (D) and tighten or replace as needed.
10. Install storage tray.
11. Close hood.
12. Tip seats back.
13. Lower cargo box.

OUMX068.0000C4B-19-23JUN15

Checking Spark Arrestor

CAUTION: Touching hot surfaces can burn skin. The engine, components, and fluids will be hot if the engine has been running. Allow the engine to cool before servicing or working near the engine and components.

Service Engine

1. Park the vehicle safely. (See Parking Safely in the SAFETY section.)
2. Allow vehicle to cool completely.

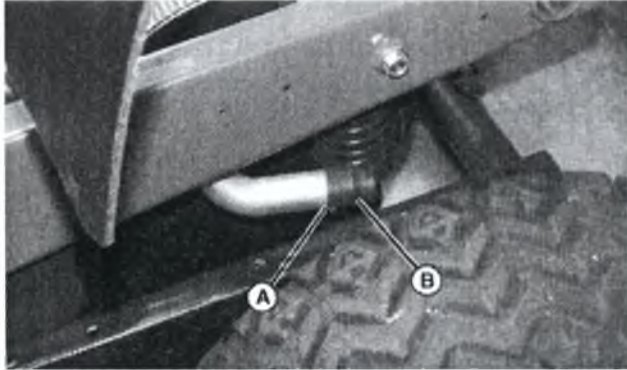

MXAL42953—UN—15MAR13

3. Remove screw (A) securing spark arrester (B) to muffler exhaust pipe. Retain the screw.
4. Remove spark arrester.
5. Make sure deflector screen inside arrester is not plugged or damaged:
 - If plugged, spray with carburetor/choke cleaner and blow dry with low pressure compressed air.
 - If damaged, replace spark arrester.
6. Install spark arrester with original hardware.

JG81906.0000735-19-01APR13

Service Transmission

Transaxle Oil

Use the appropriate oil viscosity based on these air temperature ranges. Operating outside of these recommended oil air temperature ranges may cause premature hydrostatic transmission or hydraulic system failures.

IMPORTANT: Mixing of LOW VISCOSITY HY - GARD™ and HY - GARD™ oils is permitted. DO NOT mix any other oils in this transmission. DO NOT use engine oil or "Type F" (Red) Automatic Transmission Fluid in this transmission.

John Deere J20C HY-GARD™ transmission and hydraulic oil is recommended. John Deere J20D Low Viscosity HY-GARD™ transmission and hydraulic oil may be used, if within the specified temperature range.

Other oils may be used if above recommended John Deere oils are not available, provided they meet one of the following specifications:

- John Deere Standard JDM J20C;
- John Deere Standard JDM J20D.

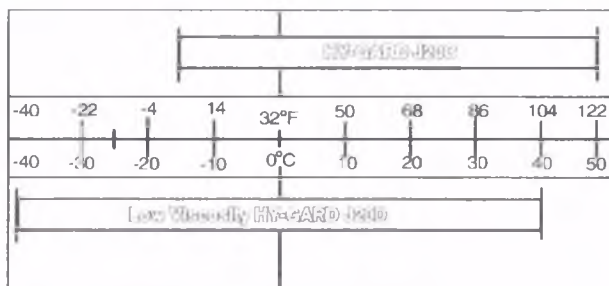

MXAL42954—UN—15MAR13
JG81906.0000736-19-01APR13

4WD Front Differential Oil

Use the appropriate oil viscosity based on these air temperature ranges. Operating outside of these recommended oil air temperature ranges may cause premature hydrostatic transmission or hydraulic system failures.

IMPORTANT: Mixing of LOW VISCOSITY HY - GARD™ and HY - GARD™ oils is permitted. DO NOT mix any other oils in this transmission. DO NOT use engine oil or "Type F" (Red) Automatic Transmission Fluid in this transmission.

John Deere J20D Low Viscosity HY-GARD™ transmission and hydraulic oil is recommended.

Other oils may be used if above recommended John Deere oils are not available, provided they meet the following specifications:

- John Deere Standard JDM J20D.

JG81906.0000737-19-01APR13

Checking 4WD Front Differential Oil Level

1. Park machine safely. (See Parking Safely in the SAFETY section.) Allow machine to cool down for at least one hour.

IMPORTANT: Dirt and debris in oil may cause damage to the 4WD differential. Clean area around opening before removing plug.

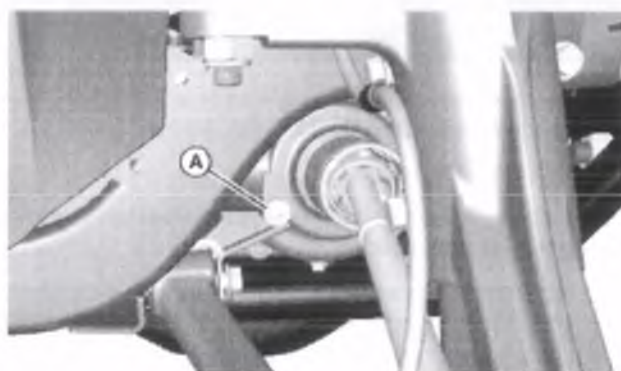

MXAL42955—UN—15MAR13

Left front wheel removed for clarity.

2. Remove fill plug (A) located on right side of 4WD front differential.
3. Oil should be level with the bottom of the fill port. If oil level is low:
 - a. Add oil through fill port until level is correct.
 - b. Install and tighten fill plug to specification.

Specification

Fill Plug—Torque: 11 - 40 N m (8 - 30 lb-ft)

JG81906.0000738-19-05APR13

Changing 4WD Front Differential Oil

NOTE: It may be necessary to remove front skid plate to access drain plug.

1. Operate machine to warm 4WD front differential oil.
2. Park machine safely. (See Parking Safely in the SAFETY section.)

IMPORTANT: Dirt and debris in oil may cause damage to the 4WD differential. Clean area around opening before removing plug.

Service Transmission

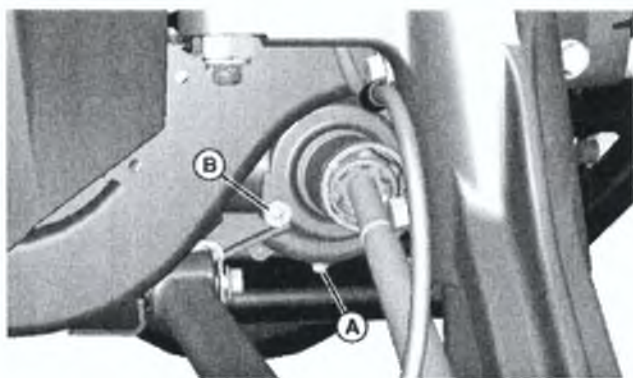

MXAL42956—UN—15MAR13

Left front wheel removed for better view.

3. Position drain pan under 4WD front differential drain plug (A) at bottom of housing.
4. Remove fill plug (B) located on right side of 4WD front differential.
5. Remove 4WD front differential drain plug (A) and allow oil to drain.
6. Check washer on drain plug. Replace if missing or in poor condition.
7. Install and tighten drain plug to specification after all oil has drained.

Specification

Drain Plug—Torque. 7-14 N·m (5-10 lb-ft)

8. Add oil until the level is even with the bottom of the fill port.
9. Install and tighten fill plug to specification.

Specification

Fill Plug—Torque. 11-40 N·m (8-30 lb-ft)

10. Check 4WD front differential oil level again after the first several hours of operation.

JG81906,0000739-19-05APR13

Checking Transaxle Oil Level

IMPORTANT: Hot hydraulic oil will expand and show incorrect oil level. Check oil level:

- When oil is cold.
- With engine not running.

1. Park the vehicle safely. (See Parking Safely in the SAFETY section.)
2. Raise and secure cargo box.

IMPORTANT: Dirt and debris in oil may cause damage to the transaxle. Clean area around opening before removing dipstick.

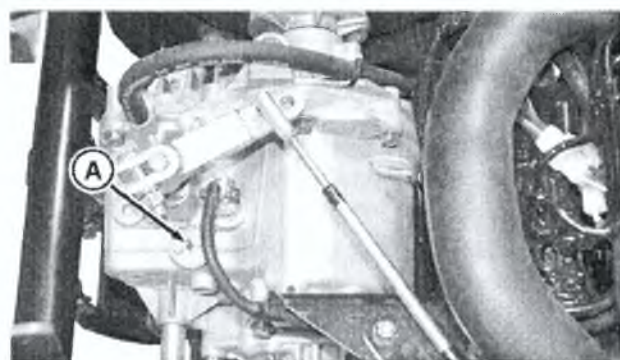

MXT008926—UN—12SEP13

3. Remove dipstick (A) located on the top of the transaxle housing. Wipe dipstick clean.
4. Check oil level by setting dipstick on threads in transaxle case, then removing and checking oil level.
5. Add oil as needed through the dipstick fill hole.
6. Install and tighten dipstick.
7. Lower the cargo box.

OUO2005,00001C3-19-12SEP13

Changing Transaxle Oil

1. Park the vehicle safely. (See Parking Safely in the SAFETY section.)
2. Raise and secure cargo box.

IMPORTANT: Dirt and debris in oil may cause damage to the transaxle. Clean area around opening before removing dipstick.

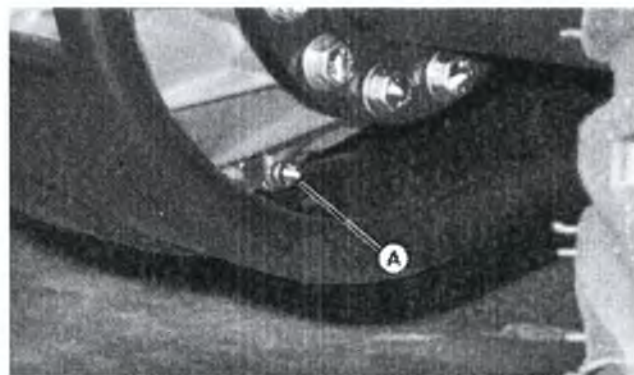

MXAL42958—UN—15MAR13

3. Position drain pan under transaxle drain plug (A).
4. Remove plug and drain oil.
5. Check washer on drain plug. Replace if missing or in poor condition.
6. Install and tighten drain plug to specification.

Specification

Transaxle Drain Plug—Torque. 44 - 54 N·m (32.5 - 39.9 lb-ft)

Service Transmission

7. Remove dipstick located on top of transaxle housing. Wipe dipstick clean.
8. Add recommended oil.
9. Check oil level by setting dipstick on threads in transaxle case, then removing and checking oil level.
10. Wait for two minutes then check oil level. Add oil if necessary.
11. Install dipstick and tighten.
12. Lower the cargo box.

JG81906.000073B-19-05APR13

Checking Drive Belt

⚠ CAUTION: Rotating parts can catch fingers, loose clothing, or long hair. Wait for engine and all moving parts to stop before leaving operator's station to adjust or service machine.

1. Park the vehicle safely. (See Parking Safely in the SAFETY section.)
2. Raise and secure cargo box.
3. Rotate and inspect belt for wear or damage.

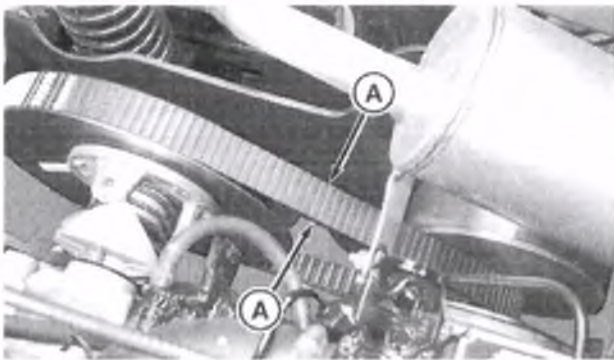

MXT008927—UN—12SEP13

4. Measure the top surface of the belt width at (A). Dimension should be a minimum of 27 mm (1.1 in.).
5. Replace belt if worn beyond limit.
6. Lower the cargo box.

OUO2005.00001C4-19-12SEP13

Replacing Drive Belt

⚠ CAUTION: Rotating parts can catch fingers, loose clothing, or long hair. Wait for engine and all moving parts to stop before leaving operator's station to adjust or service machine.

1. Park the vehicle safely. (See Parking Safely in the SAFETY section.)

2. Raise and secure cargo box.

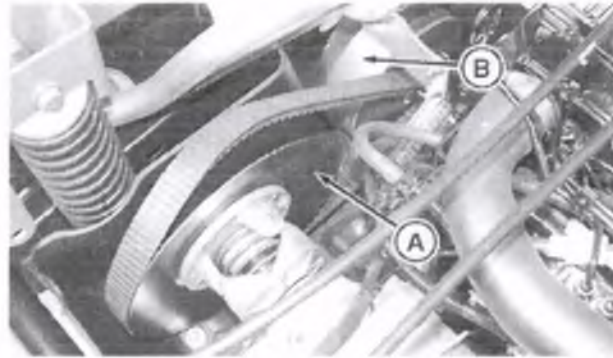

MXT008928—UN—12SEP13

3. Route the belt over pulley (A) of the driven clutch. Rotating the driven pulley will aid in removing the belt.
4. Route belt over drive pulley (B) to remove.
5. Install new belt by routing over drive pulley and then over the driven clutch pulley.
6. Lower the cargo box.

OUO2005.00001C5-19-12SEP13

Checking Secondary Driven Clutch Buttons

1. Park the vehicle safely. (See Parking Safely in the SAFETY section.)
2. Raise and secure cargo box.

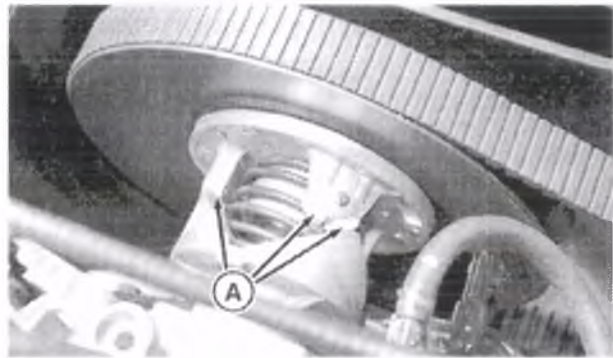

MXT008929—UN—12SEP13

3. Check for missing or worn clutch buttons (A).
 - There should not be any excessive wear, or metal-to-metal contact.
 - If replacement is necessary, see your John Deere dealer.
4. Lower the cargo box.

OUO2005.00001C6-19-12SEP13

Cleaning Primary Drive Clutch

IMPORTANT: Never lubricate any part of the primary drive clutch.

Service Transmission

1. Park the vehicle safely. (See Parking Safely in the SAFETY section.)
2. Raise and secure cargo box.

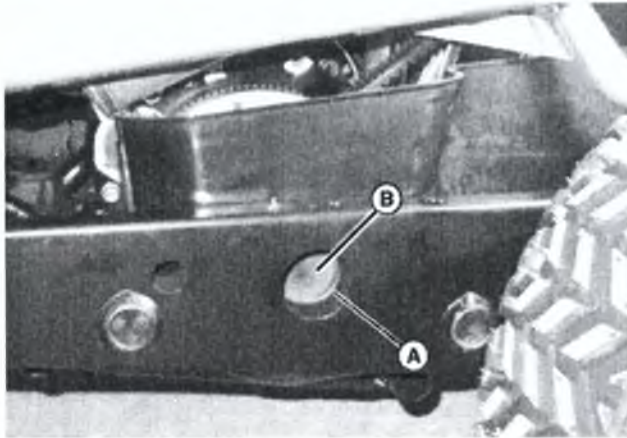

MXAL42962—UN—15MAR13

3. Through access hole (A), remove clutch cover plug (B).

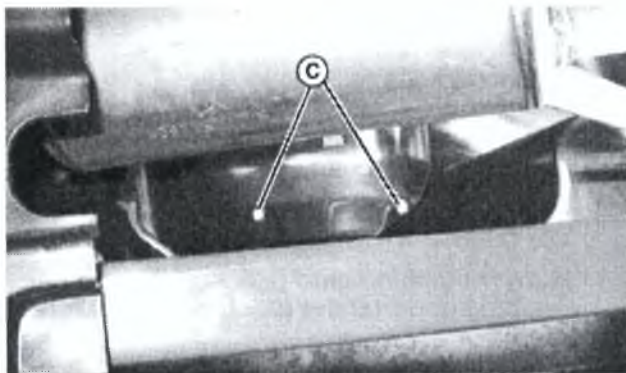

MXAL42963—UN—15MAR13

4. Remove three screws (C) securing clutch cover. Pull cover away from clutch.

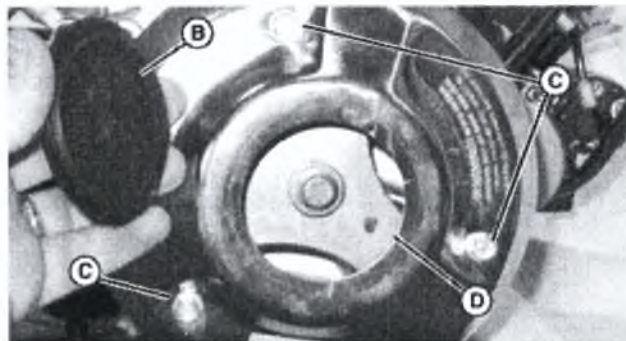

MXAL42964—UN—15MAR13

Engine removed for clarity. Engine does not need to be removed to clean clutch.

5. Through access hole (D), use compressed air to blow dust and debris out of clutch. Also blow dust and debris out from underneath the belt along the main shaft.
6. Install clutch cover and tighten screws.

Specification

Screws—Torque. 8 - 11 N·m
6 - 8 lb.-ft.

7. Install clutch cover plug (B).

8. Lower the cargo box.

JG81906,000073F-19-01APR13

Service Steering & Brakes

Brake Fluid

The following heavy duty brake fluid is **PREFERRED** for all drum and disc brakes:

- Brake Fluid - DOT4
Other brake fluids may be used if they provide the following:
- Conforms to Motor Vehicle Safety Standard No. 116.
- Minimum wet boiling point 155°C (311°F).
- Minimum dry boiling point 230°C (446°F) to prevent vapor lock.

JG81906 0000740-19-01APR13

Checking Brake Fluid Level

IMPORTANT: Avoid contamination of the brake fluid.

Thoroughly clean area around the filler cap before removing. Do not open the brake fluid reservoir cap unless absolutely necessary.

Use extreme care when filling the reservoir. Fluid spilled on painted surfaces can cause damage.

Use only brake fluid from a sealed container.

1. Park vehicle safely. (See Parking Safely in the Safety section.)
2. Open hood.
3. Carefully clean area around reservoir cap.

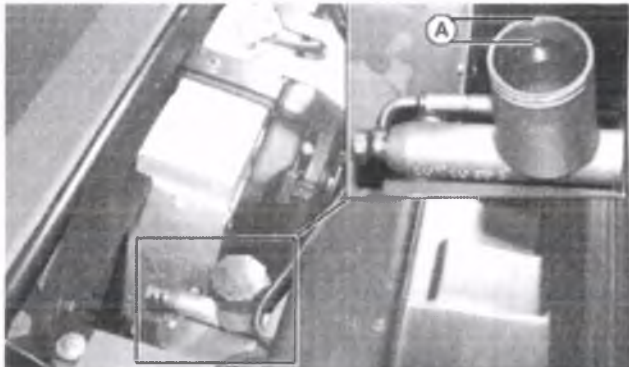

MXAL42965—UN—15MAR13

4. Remove reservoir cap and visually check fluid level.
 - Fluid levels must be maintained.

Specification

Fluid Maintenance—12 - 13 mm 0.47 - 0.51 in.

5. If fluid is low:

- Add fluid to maintain level within specification.

Specification

Fluid Maintenance—12 - 13 mm 0.47 - 0.51 in.

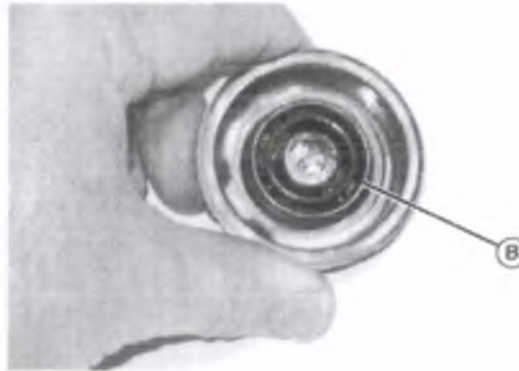

MXAL42966—UN—15MAR13

6. Check reservoir cap bellows (B) are in place and not damaged.
7. Install reservoir cap.
8. Close hood.

JG81906 0000741-19-01APR13

Checking Brake Pads

1. Park machine safely. (See Parking Safely in the SAFETY section.)

CAUTION: Avoid injury! The machine can fall or slip from an unsafe lifting device or supports.

- Use a safe lifting device rated for the load to be lifted.
- Lower machine onto jack stands or other stable supports and block wheels before servicing.

IMPORTANT: Avoid damage! Place jack stands under frame, not under transmission or engine, when raising or supporting machine.

2. Raise machine with a safe lifting device and lower machine onto jack stands or other stable supports. Block wheels remaining on the ground to prevent machine movement

NOTE: If present, remove cap (A) before removing the wheel.

Service Steering & Brakes

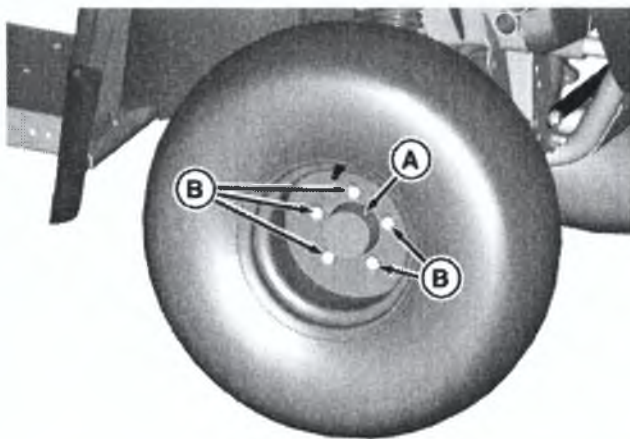

MXT011026—UN—04SEP14

3. Remove the wheel bolts (B).
4. Remove the wheel assembly.

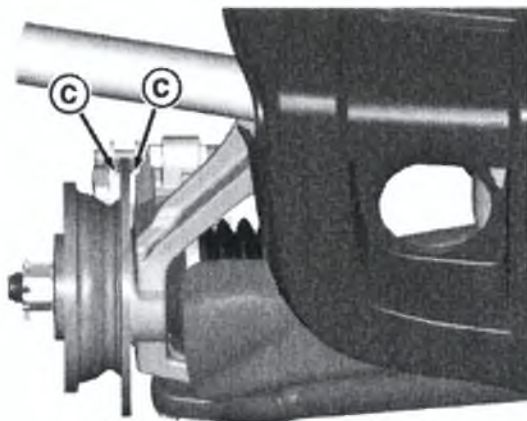

MXT011027—UN—04SEP14

5. Inspect brake pads friction material (C) for wear or damage. Check each pads friction material thickness. Material must not be less than minimum specification. If below specification or brake pad friction material is damaged, see your John Deere dealer for replacement service.

Specification

Pad Friction
Material—Thickness 1 mm (3/64 in.)

6. Install wheel assembly with valve stem to the outside.
7. Tighten wheel bolts evenly in alternating sequence until snug.
8. Repeat procedure for remaining three wheels.
9. Lower machine to the ground.
10. Tighten wheel bolts to 108 N·m (80 lb.-ft.).

OUMX068,0000986-19-23SEP14

Checking Brake Lines

1. Park machine safely. (See Parking Safely in the SAFETY section.)
2. Protect any painted surfaces from expelled brake fluid and wipe any areas of excess brake fluid.
3. Open hood.

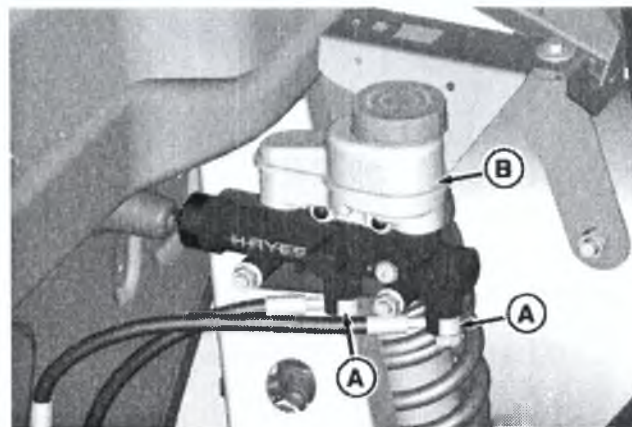

MXT011028—UN—04SEP14

4. Check brake line fittings (A) at bottom of reservoir (B) for leaks.
5. Tighten brake line fitting banjo bolts, as needed, to specification.

Specification

Banjo Bolts—Torque 24 N·m (18 lb.-ft.)

6. Rotate wheels to provide access to brake calipers.

NOTE: Each caliper has two bleeder screws. If bleeding brakes is necessary, use only the upper screw (F) to bleed brake calipers.

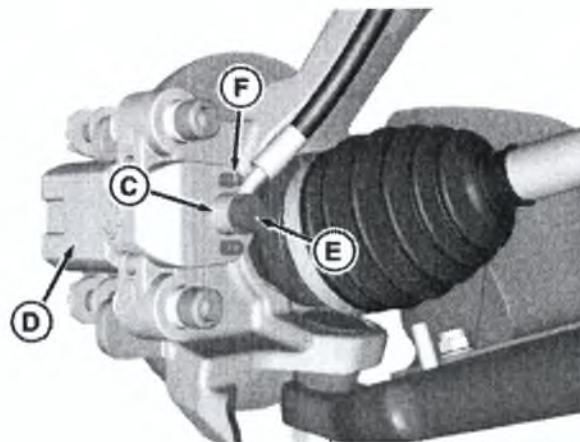

MXT011029—UN—04SEP14

Picture Note: Front shown.

Service Steering & Brakes

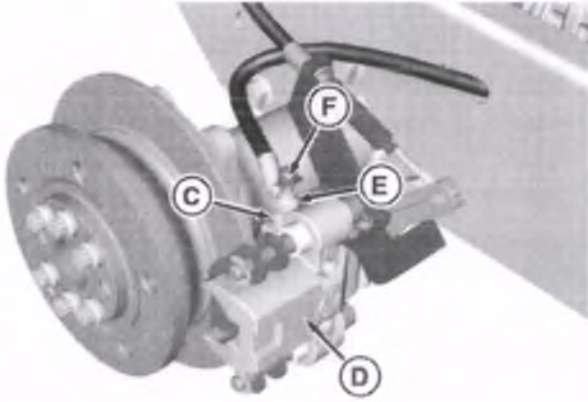

MXT011030—UN—04SEP14

Picture Note: Rear shown.

7. Inspect lower brake line fitting (C) on each brake caliper (D) for leaks. Tighten brake line fitting banjo bolt (E), as needed, to specification.

Specification

Banjo Bolt—Torque. 27 N m (20 lb.-ft.)

8. Lower hood.
9. Start vehicle and press brake pedal. If leaks are still found, see your John Deere Dealer for service.

OUMX068,0000987-19-23SEP14

Adjusting Park Brake

For proper adjustment of the park brake system, see your John Deere Dealer.

JG81906,0000742-19-01APR13

Service Electrical

Service the Battery Safely



MXAL42967—UN—15MAR13

CAUTION: Battery electrolyte contains sulfuric acid. It is poisonous and can cause serious burns:

- Wear eye protection and gloves.
- Keep skin protected.
- If electrolyte is swallowed, get medical attention immediately.
- If electrolyte is splashed into eyes, flush immediately with water for 15-30 minutes and get medical attention.
- If electrolyte is splashed onto skin, flush immediately with water and get medical attention if necessary.

The battery produces a flammable and explosive gas. The battery may explode:

- Do not smoke near battery.
- Wear eye protection and gloves.
- Do not allow direct metal contact across battery posts.
- Remove negative cable first when disconnecting.
- Install negative cable last when connecting.

OUMX068.000033E-19-10OCT13

Checking the Battery (Sealed Batteries)

NOTE: Do not attempt to open, add fluid or service battery. Any attempt to do so will void warranty.

- Keep battery and terminals clean.
- Keep battery bolts tight.
- Keep small vent holes open.

IMPORTANT: This battery comes fully charged. If the machine is not used by the service expiration date indicated on the battery, charge the battery.

- Recharge, if necessary, at 6-10 amperes for 1 hour.

JG81906.0000744-19-08APR13

Removing and Installing Battery

Removing

1. Park the vehicle safely. (See Parking Safely in the SAFETY section.)
2. Raise passenger seat.

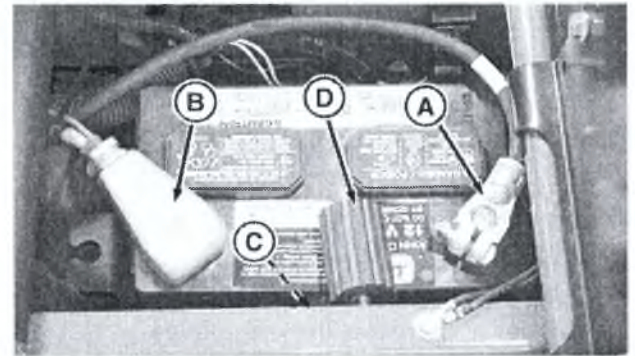

MXT008930—UN—12SEP13

3. Disconnect all black negative cables (A) from battery first.
4. Slide back rubber protective cover (B) and disconnect all red positive cables.
5. Loosen hardware (C) that secures battery hold-down (D) and pivot hold-down away from battery.
6. Lift battery from vehicle.

Installing

1. Install battery into vehicle with negative (-) terminal positioned toward front of vehicle and the battery seated properly in the battery tray.
2. Pivot battery hold-down firmly against battery and tighten retaining hardware to secure.
3. Connect all red positive cables to positive (+) battery terminal first. Tighten the connections.
4. Connect all black negative cables to negative (-) battery terminal. Tighten the connections.
5. Apply spray lubricant to battery terminals to help prevent corrosion.
6. Slide protective cover down the battery positive cable and seat it over the positive (+) terminal.

QUO2005.00001C7-19-12SEP13

Cleaning Battery and Terminals

1. Park machine safely. (See Parking Safely in the SAFETY section.)
2. Disconnect and remove battery.

Service Electrical

- Wash battery with solution of four tablespoons of baking soda to one gallon of water. Be careful not to get the soda solution into the cells.
- Rinse the battery with plain water and dry.
- Clean terminals and battery cable ends with wire brush until bright.
- Install battery.
- Attach cables to battery terminals, beginning with the positive cable, using washers and nuts.
- Apply spray lubricant to terminal to prevent corrosion.

JG81906 0000746-19-01APR13

Install negative booster cable away from moving parts in the engine compartment, such as belts and fan blades.

- Connect the other end (F) of negative (-) booster cable to a metal part of the disabled machine engine block away from battery.
- Start the engine of the disabled machine and run machine for several minutes.
- Carefully disconnect the booster cables in the exact reverse order: negative cable first and then the positive cable.

JG81906.0000747-19-01APR13

Using Booster Battery

CAUTION: The battery produces a flammable and explosive gas. The battery may explode:

- Do not smoke or have open flame near battery.
- Wear eye protection and gloves.
- Do not jump start or charge a frozen battery. Warm battery to 16°C (60°F).
- Do not connect the negative (-) booster cable to the negative (-) terminal of the discharged battery. Connect at a good ground location away from the discharged battery.

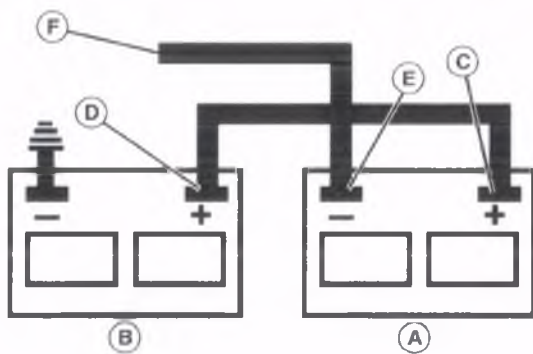

MXAL42969—UN—15MAR13

A—Booster Battery
B—Disabled Vehicle Battery

- Connect positive (+) booster cable to booster battery (A) positive (+) post (C).
- Connect the other end of positive (+) booster cable to the disabled vehicle battery (B) positive (+) post (D).
- Connect negative (-) booster cable to booster battery negative (-) post (E).

IMPORTANT: Electric charge from booster battery can damage machine components. Do not install negative booster cable to machine frame. Install only to the engine block.

Adjusting Headlights

- Orient machine so it is on a level surface facing a flat, vertical surface such as a wall. Move the machine as close as possible to this surface.

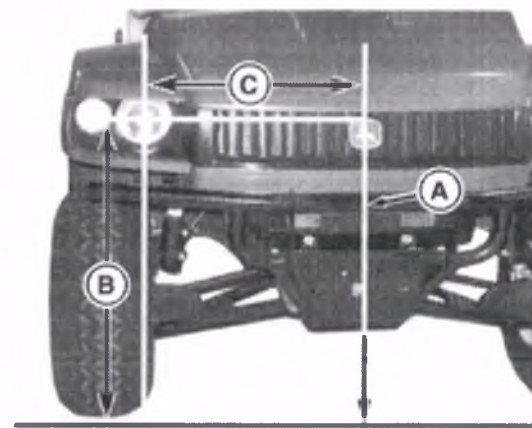

MXT006744—UN—28JAN13

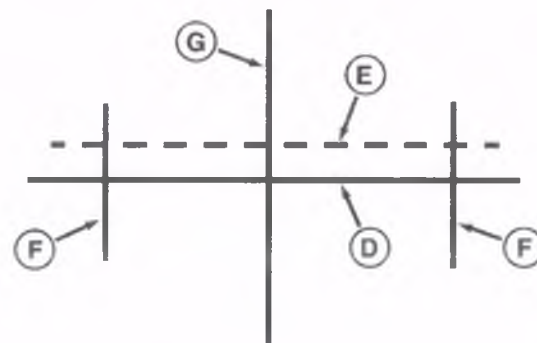

MXT006745—UN—28JAN13

- Draw or mark a vertical line (A) on the wall corresponding to the centerline of the machine.
- Move the machine straight back from the wall until the headlights are 7.62 m (25 ft) from the wall.

Service Electrical

4. Measure the distance (B) from the ground to the geometric center of one of the headlight lenses.
5. Measure the distance (C) from the geometric center of the headlight to the machine centerline.
6. Draw or mark a horizontal line (D) on the wall exactly 76.2 mm (3 in) lower than measurement (E), and long enough to extend past the centerlines of the two headlights.
7. Draw or mark vertical lines (F) on the wall to the right and left of the machine centerline (G) at the distance (C) measured earlier to the centerline of each headlight.
8. Turn the headlight switch to the full on position.

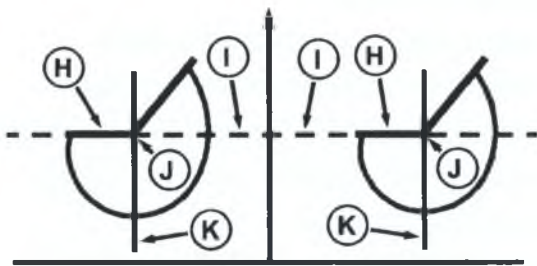

MXT020710—UN—07AUG17
Right-Hand Drive Shown

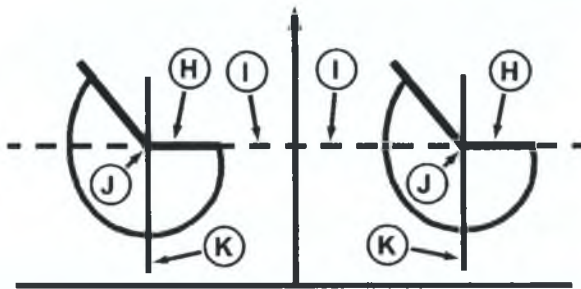

MXT020711—UN—07AUG17
Left-Hand Drive Shown

9. By turning the two lower headlight screws, adjust the vertical aim of the headlight so the top horizontal cutoff (H) of each beam pattern is located along the horizontal line (I) drawn on the wall.
10. By turning the upper headlight screw, adjust the horizontal aim of the beams so the corner (J) where the top cutoff of the beam pattern begins to slope upwards is located at the vertical marks (K).

MX10673,0000064-19-07AUG17

Servicing the Alternator Belt

⚠ CAUTION: Avoid injury! Rotating parts can catch fingers, loose clothing, or long hair. Wait for engine and all moving parts to stop before leaving operator's station to adjust or service machine.

Checking Belt Tension

1. Park machine safely. (See Parking Safely in the SAFETY section.) Allow engine to cool.
2. Raise and secure cargo box.

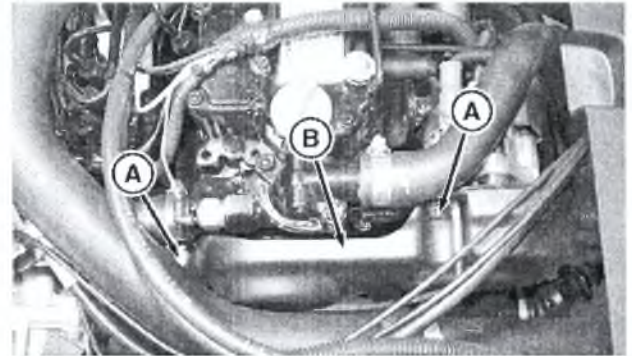

MXT008931—UN—12SEP13

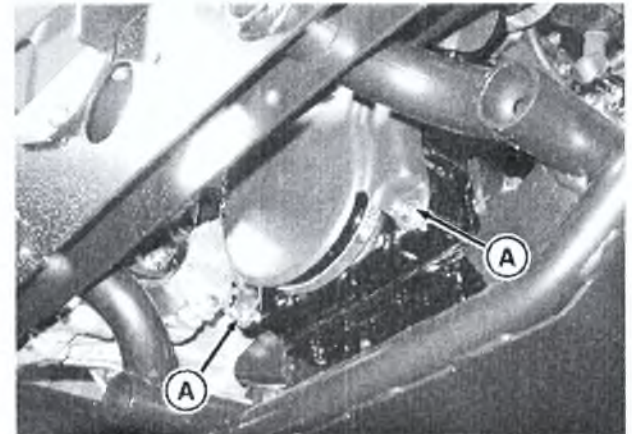

MXT008932—UN—12SEP13

3. Remove hardware (A). Lift belt guard (B) from vehicle.

Service Electrical

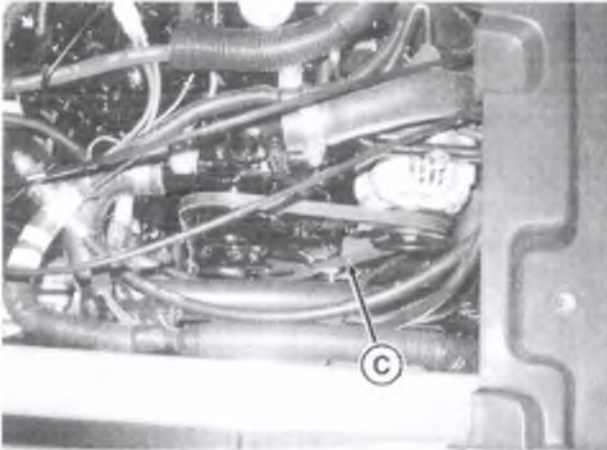

MXT008933—UN—12SEP13

4. Apply moderate thumb pressure to belt halfway between pulleys (C). Belt should deflect approximately 9 mm (3/8 in.).
5. Adjust belt tension if deflection is more or less than specified.
6. Replace fan belt if worn or damaged.

Adjusting Belt Tension

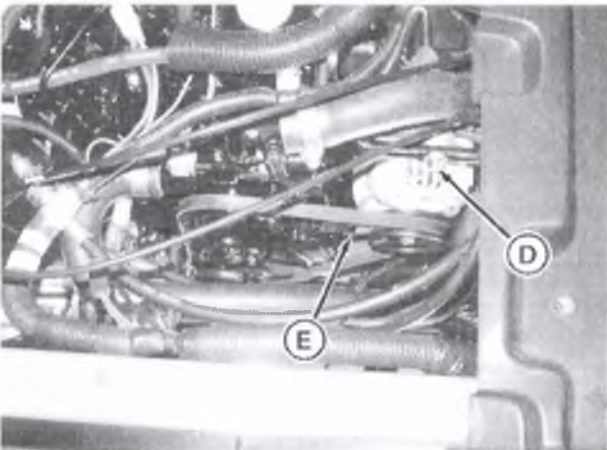

MXT008934—UN—12SEP13

1. Loosen adjusting bolt (D).
2. Loosen mounting bolt (E).
3. Apply outward pressure to alternator housing until tension is correct.
4. Tighten bolts.
5. Check belt tension.
6. Install belt guard and tighten hardware completely.
7. Lower the cargo box.

Replacing Belt

NOTE: Replace alternator belt if excessive wear, damage or stretching is detected.

1. Park machine safely. (See Parking Safely in the SAFETY section.) Allow engine to cool.

2. Tip passenger seat forward.
3. Disconnect black negative (-) cable from battery.
4. Raise and secure cargo box.
5. Remove belt guard hardware. Lift belt guard from vehicle.
6. Loosen alternator adjusting bolt.
7. Loosen alternator mounting bolt.
8. Apply inward pressure to alternator housing.
9. Remove belt from alternator sheave, coolant pump sheave and crankshaft sheave.
10. Install new belt onto sheaves.
11. Apply outward pressure to alternator housing until tension is correct.
12. Tighten mounting and adjusting bolts.
13. Check belt tension. Adjust as necessary.
14. Install belt guard and tighten hardware completely.
15. Connect black negative (-) cable to battery.
16. Lower the cargo box.
17. Lower the seat.

OUC02005,00001CB-19-12SEP13

Checking and Replacing Fuses

IMPORTANT: Avoid damage! If incorrect replacement fuses are used, the electrical system can be damaged. Replace the bad fuse with a fuse of the same amperage rating.

1. Park the machine safely. (See Parking Safely in the SAFETY section.)
2. Raise hood and remove storage tray.

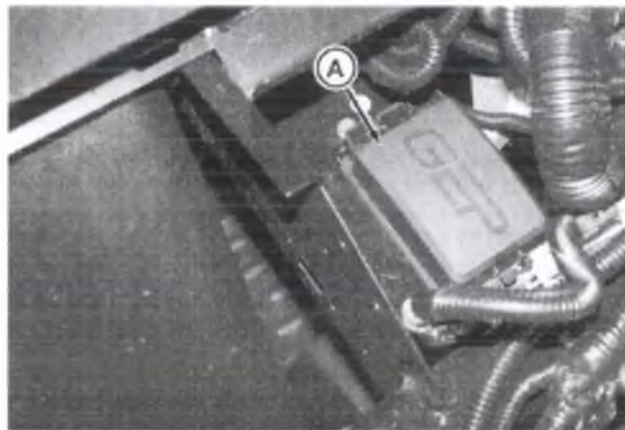

MXT020285—UN—14JUL17

3. Remove cover (A).

Service Electrical

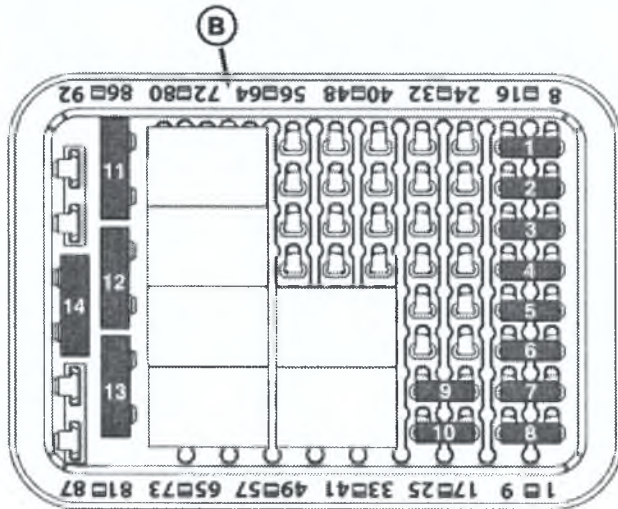

MXT020286—UN—14JUL17

4. Pull fuse from the fuse block (B).
5. Fuse identification:

Position	Circuit	Fuse Size
1	Instrument Cluster Control	20 A
2	Fuel Pull In	30 A
3	Fan Relay	30 A
4	Starter	20 A
5	Key Switch	20 A
6	Dash Power Port	10 A
7	Service Brake	10 A
8	Center Power Port	10 A
9	Diagnostic Port	5 A
10	Headlights	10 A
11	Glow Plugs	30 A
12	Key Switch Relay	30 A
13	Front Power	40 A
14	Rear Power	40 A

6. Look for a broken filament in the fuse (See Checking Fuse Filaments in SERVICE MISCELLANEOUS).
7. Push a new fuse of the correct amperage rating into the proper position in the fuse block.
8. Install fuse block cover.
9. Install storage tray and lower hood.
10. Raise the passenger seat.

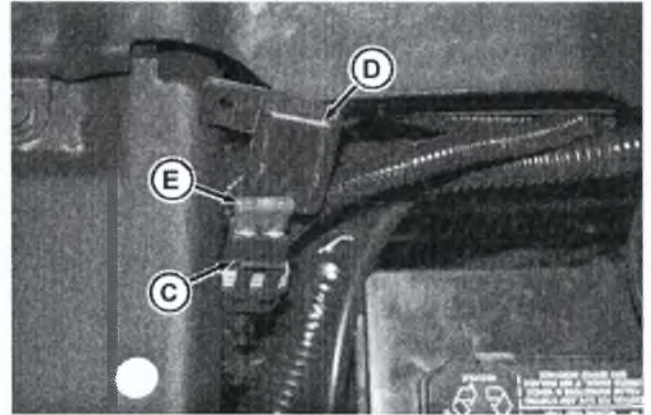

MXT020298—UN—24JUL17

11. Locate fuse holder (C) near the battery.
12. Remove cover (D) and remove fuse (E).
13. Look for a broken filament in the fuse (See Checking Fuse Filaments in SERVICE MISCELLANEOUS).
14. Push a new fuse of the correct amperage rating into the fuse holder:

Position	Circuit	Fuse Size
—	Cab Power	40 A

15. Install cover on the fuse holder.
16. Lower the passenger seat.

OUMX068,000132F-19-25JUL17

Checking and Replacing Fuses (Homologation)

IMPORTANT: Avoid damage! If incorrect replacement fuses are used, the electrical system can be damaged. Replace the bad fuse with a fuse of the same amperage rating.

1. Park the machine safely. (See Parking Safely in the SAFETY section.)
2. Raise hood and remove storage tray.

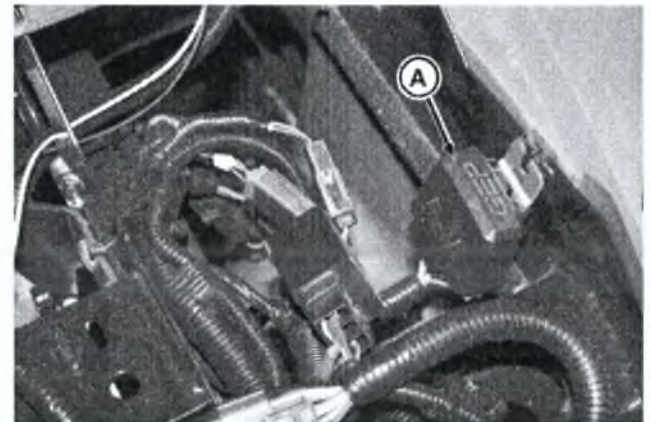

MXT020287—UN—14JUL17

Service Electrical

3. Locate the fuse block (A) for the homologation lights harness. Remove fuse block from cover.

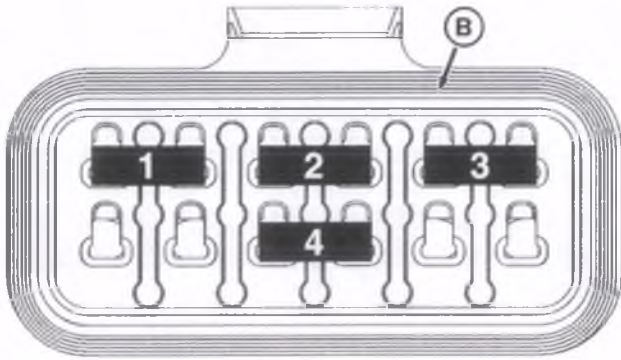

MXT020267—UN—06JUL17

4. Pull fuse from the fuse block (B).
5. Fuse identification:

Position	Circuit	Fuse Size
1	Right Front Marker Light	5 A
2	Left Front Marker Light	5 A
3	Headlight (High Beam)	5 A
4	Headlight (Low Beam)	7.5 A

6. Look for a broken filament in the fuse (See Checking Fuse Filaments in SERVICE MISCELLANEOUS).
7. Push a new fuse of the correct amperage rating into the proper position in the fuse block.
8. Install fuse block into cover.
9. Install storage tray and lower hood.

OUMX068 0001330-19-14JUL17

Service Miscellaneous

Using Proper Fuel (Diesel)

Use the proper diesel fuel to help prevent decreased engine performance and increased exhaust emissions. Failure to follow the fuel requirements listed below can void your engine warranty.

Consult your local fuel distributor for properties of the diesel fuel in your area.

In general, diesel fuels are blended to satisfy the low temperature requirements of the geographical area in which they are marketed.

Diesel fuels specified to EN 590 or ASTM D975 are recommended.

Required fuel properties

In all cases, the fuel shall meet the following properties:

Cetane number of 45 minimum. Cetane number greater than 50 is preferred, especially when temperatures are below -20°C (-4°F) or elevations above 1500 m (5000 ft).

Cold Filter Plugging Point (CFPP) should be at least 5°C (9°F) below the expected lowest temperature or **Cloud Point** below the lowest ambient temperature.

Fuel lubricity should pass a maximum scar diameter of 0.45 mm as measured by ASTM D6079 or ISO 12156-1.

IMPORTANT: Improper fuel additive usage may cause damage on fuel injection equipment of diesel engines.

If a fuel of low or unknown lubricity is used, addition of John Deere PREMIUM DIESEL FUEL CONDITIONER at the specified concentration is recommended.

Sulfur content

- Diesel fuel quality and fuel sulfur content must comply with all existing emissions regulations for the area in which the engine operates.
- Use only ultra low sulfur diesel (ULSD) fuel with a maximum of 0.0015% (15mg/kg) sulfur content.

IMPORTANT: Do not mix diesel engine oil or any other type of lubricating oil with diesel fuel.

Using Bio-Diesel Fuel

Bio-diesel fuels may be used only if the bio-diesel fuel properties meet the latest edition of ASTM D6751, ASTM D7467, EN14214, or equivalent specification.

The current maximum allowable bio-diesel concentration is a 5% blend (also known as B5) in petroleum diesel fuel.

To learn of any changes to the recommendations for bio-diesel usage with your diesel engine, ask your John Deere dealer or reference the Services and Support link on the John Deere Commercial and Consumer Equipment website.

Handling and Storing Diesel Fuel

CAUTION: Handle fuel carefully. Do not fill the fuel tank when engine is running.

Do not smoke while you fill the fuel tank or service the fuel system.

IMPORTANT: Do not use galvanized containers—diesel fuel stored in galvanized containers reacts with zinc coating in the container to form zinc flakes. If fuel contains water, a zinc gel will also form. The gel and flakes will quickly plug fuel filters and damage fuel injectors and fuel pumps.

- Fill the fuel tank at the end of each day's operation to prevent water condensation and freezing during cold weather.
- When fuel is stored for an extended period or if there is a slow turnover of fuel, add a fuel conditioner to stabilize the fuel and to prevent water condensation. Contact your fuel supplier for recommendations.

MX00654,0000119-19-06SEP13

Filling Fuel Tank

CAUTION: Fuel vapors are explosive and flammable:

- Shut engine off before filling fuel tank.
- Allow engine to cool before refueling.
- Do not smoke while handling fuel.
- Keep fuel away from flames or sparks.
- Fill fuel tank outdoors or in well ventilated area.
- Clean up spilled fuel immediately.
- Use clean approved non-metal container to prevent static electric discharge.

IMPORTANT: Dirt and water in fuel can cause engine damage:

- Clean dirt and debris from the fuel tank opening.
- Use clean, fresh, stabilized fuel.
- Fill the fuel tank at the end of each day's operation to keep condensation out of the fuel tank.
- If using a funnel, make sure it is plastic and has no screen or filter.

Fill fuel tank at the end of each day's operation to prevent condensation and freezing during cold weather.

1. Park machine safely. (See Parking Safely in the SAFETY section.)

Service Miscellaneous

2. Allow engine to cool.
3. Remove any trash from area around fuel tank cap.
4. Remove fuel tank cap slowly to allow any pressure built up in tank to escape.
5. Fill fuel tank only to bottom of filler neck. Do not overfill.
6. Install fuel tank cap.
 - Gas models: Turn cap until clicks.

JG81906.000074C-19-29JUL16

Removing and Installing Wheel Assembly

Removing

1. Park machine safely. (See Parking Safely in the SAFETY section.)

CAUTION: The machine can fall or slip from an unsafe lifting device or supports.

- Use a safe lifting device rated for the load to be lifted.
- Lower machine onto jack stands or other stable supports and block wheels before servicing.

IMPORTANT: Place jack stands under frame, not under transmission or engine, when raising or supporting machine.

2. Raise machine with a safe lifting device and lower machine onto jack stands or other stable supports. Block wheels remaining on the ground to prevent machine movement.

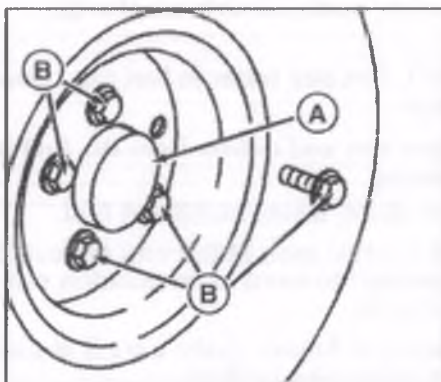

MXT009121—UN—17SEP13

Picture Note: Wheel may or may not have a cap (A) to remove when removing the wheel.

3. Remove the wheel bolts (B).

4. Remove the wheel assembly.

CAUTION: Explosive separation of tire and rim parts is possible when they are serviced incorrectly:

- Do not attempt to mount a tire without the proper equipment and experience to perform the job.

5. Take wheel assembly to an authorized service dealer for repairs.

Installing

1. Apply multipurpose grease to spindle shaft before installing wheel assembly.
2. Install wheel assembly with valve stem to the outside.
3. Tighten wheel bolts evenly in alternating sequence until snug.
4. Lower machine completely to the ground.
5. Tighten wheel bolts to 81 N·m (60 lb.-ft.).

OUO2005.00001FC-19-17SEP13

Removing and Installing Seats

Removing and Installing Bucket Seat

1. Park the machine safely. (See Parking Safely in the SAFETY section.)
2. Tip seat forward.

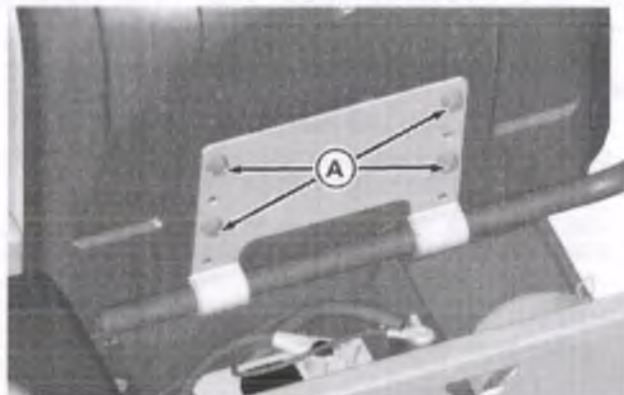

MXT014783—UN—23JUN15

3. Hold onto seat and remove screws (A).
4. Remove seat and seat bracket from the support rail.

Service Miscellaneous

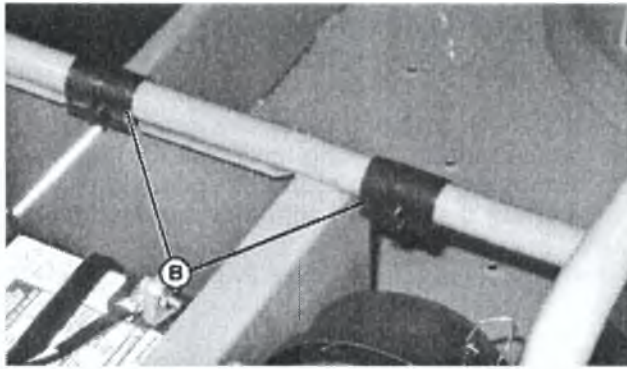

MXAL42975—UN—15MAR13

- To install seat, position seat bushings (B) on the support rail so tabs face toward rear of vehicle.

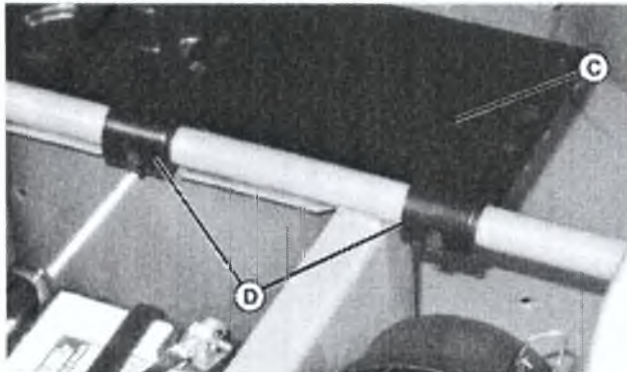

MXAL42976—UN—15MAR13

- Position seat bracket (C) onto the support rail so hinges (D) fit around rubber bushing tabs.

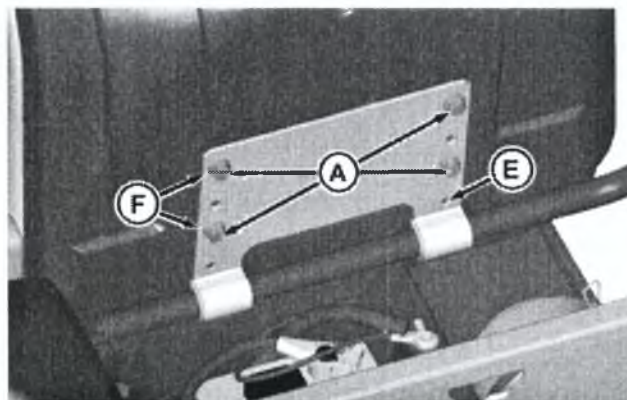

MXT014784—UN—23JUN15

Picture Note: Rear position shown.

- Rotate seat bracket upward. Position bottom of seat against bracket and align correct holes with holes in seat.
- Slide seat to the forward (E) or rearward (F) position.
- Install original screws (A) to secure the seat.
- Tighten seat bracket hardware to specification.

Specification

Seat Bracket Screws—Torque. 10 N·m (7.4 lb ft)

Removing and Installing Bench Seat

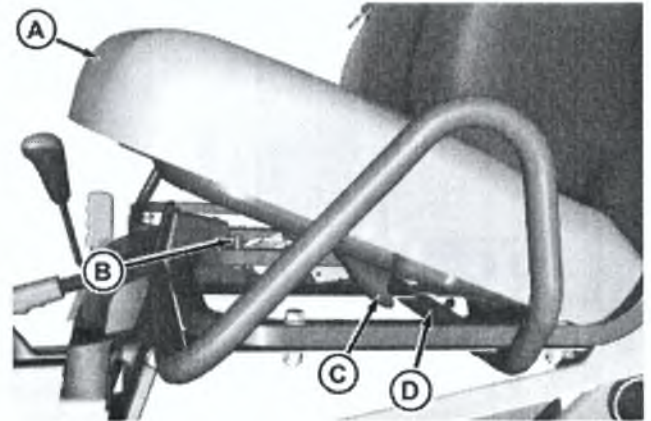

MXT020339—UN—04AUG17

- Pull up on the front of the seat (A) and remove seat from both studs (B) on the seat frame.
- Pull seat forward to remove both seat ears (C) from the rear support rail (D) on both sides of the seat base.
- To install seat, install ears (C) onto the rear support rail (D) on both sides of the seat base. Push down on the front of seat, securing seat onto studs (B).

OUMX068,0000C4E-19-04AUG17

Lifting Machine

- Park the machine safely. (See Parking Safely in the SAFETY section.)

⚠ CAUTION: Avoid injury! The machine can fall or slip from an unsafe lifting device or supports.

- Use a safe lifting device rated for the load to be lifted.
- Lower machine onto jack stands or other stable supports and block wheels before servicing.

IMPORTANT: Be certain to include any bolt heads or embossed areas inside the jack cup to prevent slipping.

NOTE: Remove all attachments before lifting machine.

Service Miscellaneous

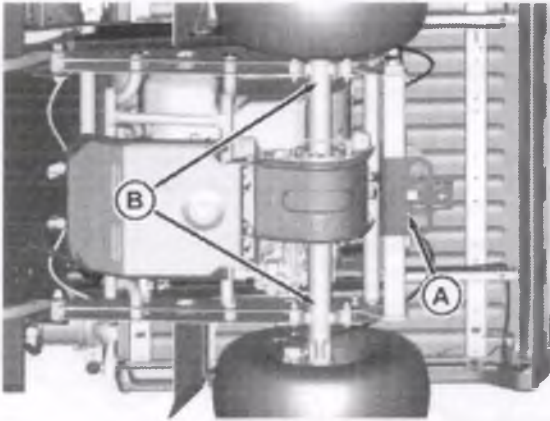

MXT020348—UN—07AUG17

Your machine model may not be shown, but jack locations are as shown.

2. Safely lift rear of the machine at frame point (A).
3. Place jack stands or other stable supports under locations (B).
4. If only lifting rear of machine, block front wheels remaining on ground to avoid movement of the machine.

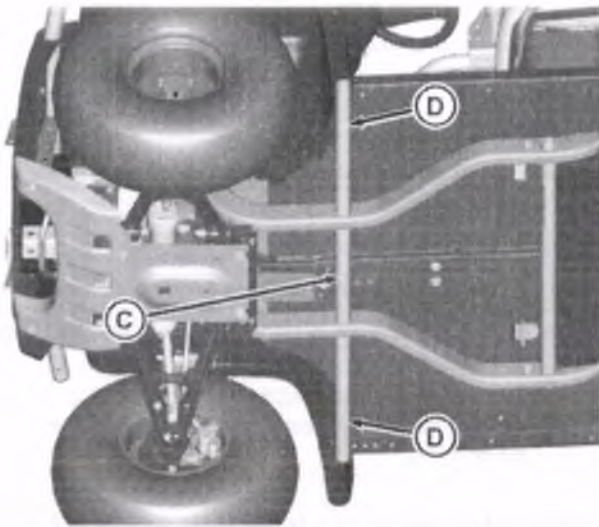

MXT020709—UN—07AUG17

Your machine model may not be shown, but jack locations are as shown.

5. Safely lift front of the machine at frame point (C) or locations (D). Place jack stands or other stable supports under two machine frame locations (D).
6. If only lifting front of machine, block rear wheels remaining on ground to avoid movement of the machine.
7. To the lower machine, lift front and/or rear of machine, and remove jack stands or supports. Lower machine.

MX10673.0000060-19-07AUG17

Opening and Closing Hood

Opening Hood

⚠ CAUTION: Rotating parts can catch fingers, loose clothing, or long hair. Wait for engine and all moving parts to stop before leaving operator's station to adjust or service machine.

1. Park the vehicle safely. (See Parking Safely in the SAFETY section.)

NOTE: On homologated machine models, use a tool like a screwdriver to unlock the latch.

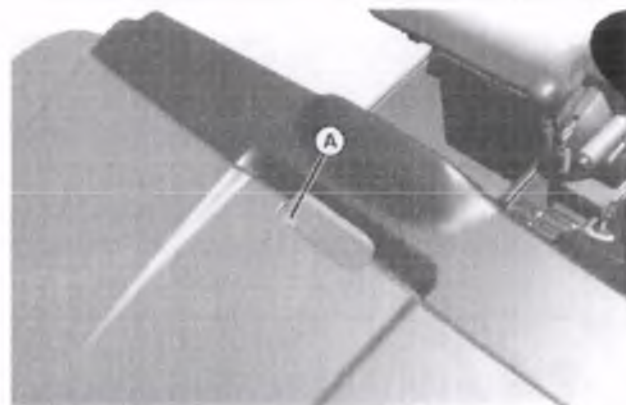

MXAL44289—UN—10APR13

2. Stand in front of machine and grasp hood lift handle.
3. Pull up on hood release handle (A) to unlock latch.
4. When the hood latch is released, pull upward on the hood to pivot to full open position.

Closing Hood

1. Grasp hood lift handle.
2. Pivot hood downward to closed position.
3. Press down on hood to latch hood in closed position.

MP47322.00F489D-19-27JUL17

Removing and Installing Storage Tray

Removing

1. Park the vehicle safely. (See Parking Safely in the SAFETY section.)
2. Open hood.
3. Remove all contents from storage tray.

Service Miscellaneous

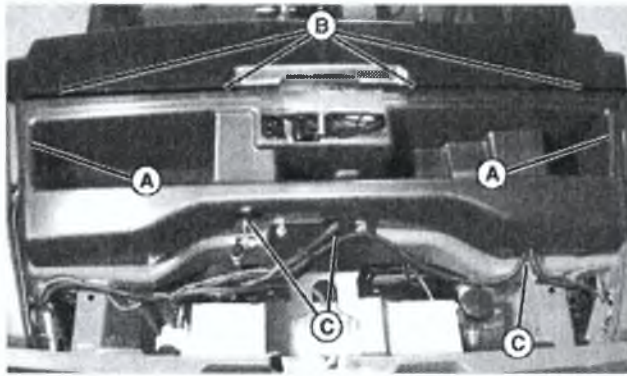

MXAL42980—UN—15MAR13

4. Grasp outer edges of the storage tray (A).
5. Flex storage tray to fit past dash panel (B) while lifting the storage tray out of machine.

Installing

1. Position storage tray over frame.

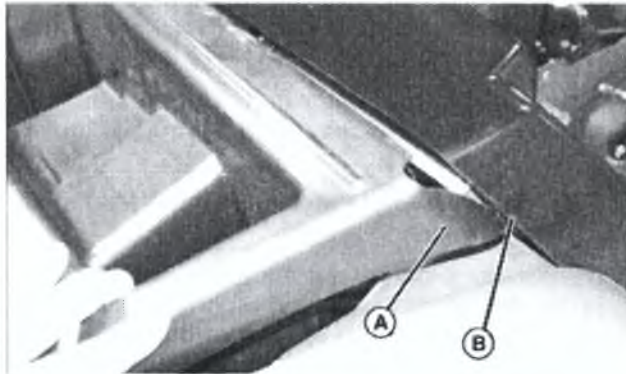

MXAL42981—UN—15MAR13

2. Flex storage tray (A) to fit under dash panel (B) while lowering storage tray into position.
3. Check alignment of cables and harnesses with routing notches (C).
4. Secure all items to prevent damage from movement while operating the machine.
5. Close hood.

JG81906,0000750-19-01APR13

Inspecting Seat Belt

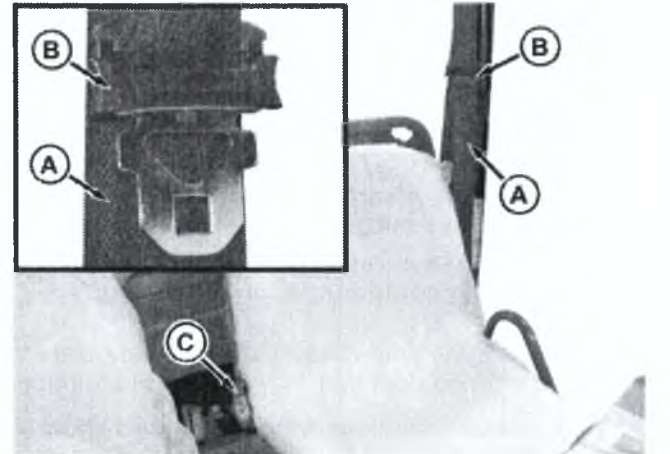

MXT014785—UN—23JUN15

IMPORTANT: Avoid damage! Do not bleach or dye webbing. Webbing could become severely weakened by this process. Do not use a pressure washer or other automatic washing machine to clean belt or connectors.

- Hand wash webbing (A) with warm water and mild soap. Rinse thoroughly and air dry.
- Inspect outer seat belt connector (B) and inner connector (C) for damage or wear. If assembly does not operate properly or if the webbing is torn or frayed, the seat belt must be replaced.

OUMX068,0000C4F-19-23JUN15

Checking Fuse Filaments

1. Remove fuse.

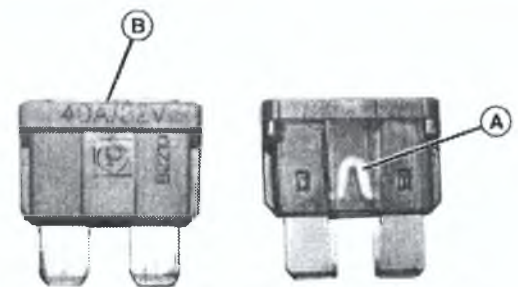

MXAL44294—UN—10APR13

2. Check visually for broken filament:

- For clear housing fuses, check filament (A).
- For all other fuses, check filament (B) in top of fuse housing.

MP47322,00F48A1-19-03APR13

Service Miscellaneous

Cleaning Plastic Surfaces

IMPORTANT: Improper care of machine plastic surfaces can damage that surface:

- Do not wipe plastic surfaces when they are dry. Dry wiping will result in minor surface scratches.
- Use a soft, clean cloth (bath towel, diaper, automotive mitt).
- Do not use abrasive materials, such as polishing compounds, on plastic surfaces.

1. Rinse hood and entire machine with clean water to remove dirt and dust that may scratch the surface.
2. Wash surface with clean water and a mild liquid automotive washing soap.
3. Dry thoroughly to avoid water spots.
4. Wax the surface with a liquid automotive wax. Use products that specifically say "contains no abrasives."

IMPORTANT: Do not use a power buffer to remove wax.

5. Buff applied wax by hand using a clean, soft cloth.

JG81906.0000752-19-01APR13

4. Apply wax to surface.

JG81906.0000753-19-01APR13

Windshield Maintenance

Inspecting Windshield

⚠ CAUTION: Avoid injury! If cracks or surface crazing are observed, or viewing through windshield is impaired, replace windshield.

1. Inspect windshield condition.
2. Fill in existing scratches.
3. Polish or wax windows regularly.

Cleaning Windshield

IMPORTANT: Avoid damage! Some cleaning compounds may attack the polycarbonate material, resulting in cracks that weaken the material.

Never use compounds that contain substances such as ammonia, gasoline, lacquer thinner, and turpentine.

Use of abrasive cleaners on windshield may cause damage.

Never use substances such as acetic acid, acetone, benzene, benzyl alcohol, brake fluid, butyric acid, carbon tetrachloride, ethyl ether, methyl alcohol, phenol, sodium sulfide, sodium hydroxide, sodium nitrate, trichloroethylene, toluene, xylene, or petroleum products.

NOTE: The windshield and windscreen are a polycarbonate material which is softer, but stronger than, glass.

The following cleaning agents are compatible with polycarbonate when used according to the manufacturer's recommendations: Formula 409® (without ammonia), Joy®, Ultra Palmolive® Original, Top Job®, Mr. Clean®, and Fantastik®.

1. Rinse as much loose dirt off as possible with warm water and a soft cloth or sponge before washing.
2. Wash with mild soap or detergent and rinse thoroughly with clean water.
3. Cleaning in direct sunlight causes streaking on surface.
4. Thoroughly dry windshield with a chamois or moist sponge to prevent water spots.

*Formula 409 is a trademark of The Clorox Company
Joy is a trademark of Procter & Gamble
Palmolive is a trademark of The Colgate-Palmolive Company
Top Job is a trademark of KIK Custom Products
Mr. Clean is a trademark of Procter & Gamble
Fantastik is a trademark of SC Johnson*

Cleaning and Repairing Metal Surfaces

Cleaning:

Follow automotive practices to care for your vehicle painted metal surfaces. Use a high-quality automotive wax regularly to maintain the factory look of your vehicle's painted surfaces.

Repairing Minor Scratches (surface scratch):

1. Clean area to be repaired thoroughly.

IMPORTANT: Do not use rubbing compound on painted surfaces.

2. Use automotive polishing compound to remove surface scratches.
3. Apply wax to entire surface.

Repairing Deep Scratches (bare metal or primer showing):

1. Clean area to be repaired with rubbing alcohol or mineral spirits.
2. Use paint stick with factory-matched colors available from your authorized dealer to fill scratches. Follow directions included on paint stick for use and for drying.
3. Smooth out surface using an automotive polishing compound. Do not use power buffer.

Service Miscellaneous

Polishing or Waxing Windshield

Minimize scratches and minor abrasions with a mild automobile polish.

Test effectiveness of polish or wax in a small corner of windshield before using on entire windshield.

OUMX068,0000BC0-19-05MAY15

Troubleshooting

Using Troubleshooting Chart

If you are experiencing a problem that is not listed in this chart, see your authorized dealer for service.

and you are still experiencing the problem, see your authorized dealer.

JG81906.0000754-19-01APR13

When you have checked all the possible causes listed

Engine

IF	CHECK
Engine will not start	Wrong engine oil viscosity. Battery has low voltage Loose or corroded battery connections Blown fuse(s). Cold start system not being used, or malfunctioning. Stale fuel/improper fuel/low fuel level Dirty or faulty fuel injectors. Fuel shut-off valve turned off. No fuel or improper fuel. Plugged fuel filter. Defective starter solenoid. Open-circuit in wiring.
Engine is hard to start	Check glow plug fuse Engine is cold. Plugged fuel filter. Engine oil viscosity too heavy. Cold start system not being used, or malfunctioning Dirty or faulty fuel injectors. Loose or corroded electrical connections. Stale or improper fuel. Blown fuse.
Engine misses under load	Stale or dirty fuel. Plugged fuel filter.
Engine vapor locks	Fuel tank vent plugged. Dirt in fuel filter.
Engine runs unevenly	Loose electrical connections. Improper fuel Stale or dirty fuel Fuel line or fuel filter plugged. Dirty or faulty fuel injectors. Plugged air intake system.
Engine overheats	Air cleaner element missing or plugged. Defective radiator cap. Engine oil low. Engine operated too long at slow engine speed. Bleed cooling system Check cooling fan switch. Check thermostat. Check water pump. Clean radiator screens Check coolant level.
Engine loses power	Engine overheating. Too much oil in engine. Fuel supply being restricted. Fuel filter plugged. Fuel line pinched or kinked. Improper fuel. Air cleaner element plugged. Injection pump out of time. Dirty or faulty fuel injectors. Improper valve clearance.
Engine knocks	Low engine speed Stale fuel. Engine overloaded Excessively early timing of fuel injection pump

OUO2005.00001CA-19-12SEP13

Troubleshooting

Electrical

IF	CHECK
Starter does not work	Loose or corroded connections. Low battery output. Sulfated or worn out battery. Faulty starter.
Starter cranks slowly	Low battery output. Sulfated or worn out battery. Engine oil too heavy. Loose or corroded connections.
Entire electrical system does not work	Blown fuse. Loose or corroded connections. Sulfated or worn out battery.
Dead battery	Shorted starter solenoid. Key switch not turned to "OFF" position. Component connected to accessory outlet left ON with engine off. Turn signal and/or hazard lights left ON with engine off. Sulfated or worn out battery. Low engine speed or excessive idling. Battery cables and terminals are dirty. Dead cell in the battery. Faulty charging system. Current draw higher than charging system output. (If several attachments are added and used frequently at the same time with the standard charging system. Especially at low engine speeds.)
Correct indicator light(s) do not come on when checking instrument panel.	Faulty bulb. Faulty wiring. Faulty switch or sensor.
Battery will not take a charge	Dead cell in battery. Loose or corroded connections. Sulfated or worn out battery. Electrolyte level low. Low engine speed or excessive idling. Faulty charging system.

JG81906,0000756-19-05APR13

Brakes

IF	CHECK
Brakes not working correctly	Brake fluid level low - check fluid level. Air in brake system, system not bleed properly. Replace worn brake pads. (See your John Deere dealer.)

JG81906,0000757-19-05APR13

Storage

Storing Safety

⚠ CAUTION: Fuel vapors are explosive and flammable. Engine exhaust fumes contain carbon monoxide and can cause serious illness or death:

- Run the engine only long enough to move the machine to or from storage.
- Do not store vehicle with fuel in the tank inside a building where fumes may reach an open flame or spark.
- Allow the engine to cool before storing the machine in any enclosure.

JG81906.0000758-19-01APR13

Preparing Machine for Storage

1. Repair any worn or damaged parts. Replace parts if necessary. Tighten loose hardware.
2. Repair scratched or chipped metal surfaces to prevent rust.
3. Remove grass and debris from machine.
4. Wash the machine with low pressure water and apply wax to metal and plastic surfaces.
5. Run machine for five minutes to dry belts and pulleys.
6. Apply light coat of engine oil to pivot and wear points to prevent rust.
7. Lubricate grease points.
8. Check tire pressure.

JG81906.0000759-19-01APR13

Preparing Fuel and Engine For Storage

Fuel:

If you have been using "Stabilized Fuel," add stabilized fuel to tank until the tank is full.

NOTE: Filling the fuel tank reduces the amount of air in the fuel tank and helps reduce deterioration of fuel.

If you are not using "Stabilized Fuel:"

1. Park machine safely in a well-ventilated area. (See Parking Safely in the SAFETY section.)

NOTE: Try to anticipate the last time the machine will be used for the season so very little fuel is left in the fuel tank.

2. Turn on engine and allow to run until it runs out of fuel.

3. For machines equipped with key switch, turn key to off position.

IMPORTANT: Stale fuel can produce varnish and plug carburetor or injector components and affect engine performance.

- Add fuel conditioner or stabilizer to fresh fuel before filling tank.

4. Mix fresh fuel and fuel stabilizer in separate container. Follow stabilizer instructions for mixing.
5. Fill fuel tank with stabilized fuel.
6. Run engine for a few minutes to allow fuel mixture to circulate through carburetor on gas engine or fuel injectors on diesel engine.

Engine:

Engine storage procedure should be used when vehicle is not to be used for longer than 60 days.

1. Change engine oil and filter while engine is warm.
2. Service air filter if necessary.
3. Clean debris from engine air intake screen.
4. On gas engines:
 - Remove spark plugs. Put 30 mL (1 oz) of clean engine oil in cylinder(s).
 - Install spark plugs, but do not connect spark plug wires.
 - Crank the engine five or six times to allow oil to be distributed.
5. Clean the engine and engine compartment.
6. Remove battery.
7. Clean the battery and battery posts. Check the electrolyte level, if your battery is not maintenance free.
8. Close fuel shut-off valve, if your machine is equipped.
9. Store the battery in a cool, dry place where it will not freeze.

NOTE: The stored battery should be recharged every 90 days.

10. Change the battery.

IMPORTANT: Prolonged exposure to sunlight could damage the hood surface. Store machine inside or use a cover if stored outside.

11. Store the vehicle in a dry, protected place. If vehicle is stored outside, put a waterproof cover over it.

JG81906.000075A-19-08APR13

Storage

Removing Machine From Storage

1. Check tire pressure.
2. Check engine oil level.
3. Check battery electrolyte level, if your battery is not maintenance free. Charge battery as necessary.
4. Install battery.
5. On gas engines: Check spark plug gap. Install and tighten plugs to specified torque.
6. Lubricate all grease points.
7. Open fuel shut-off valve, if your machine is equipped.
8. Run the engine for 5 minutes without the mower or any attachments running to allow oil to be distributed throughout engine.
9. Be sure all shields and guards or deflectors are in place.

JG81906,000075B-19-01APR13

Specifications

Engine

Make	Yanmar 3TNV70
Type	Diesel
Displacement	0.854 L (52.11 in ³)
Cylinders	3
Bore	70 mm (2.75 in)
Stroke	74 mm (2.91 in)
Intake and Exhaust Valve Clearance	0.20 mm (0.008 in)
Strokes/Cycle	4
Oil Filter	Spin On Filter
Air Cleaner	Replaceable, Paper Elements
Cooling	Liquid

OUMX068.0001328-19-14JUL17

Drive Train and Travel Speeds

Type	Belt-Driven Torque Converter With Gear-Driven Transaxle
Gear Ranges	Forward HI and LO - Neutral - Reverse
Travel Speeds:	
Travel Speeds (Forward HI)	40 km/h (25 mph)
Travel Speeds (Forward LO and Reverse)	20 km/h (12 mph)

OUMX068.0001329-19-14JUL17

Electrical System

Type	12 Volt
Battery Size	480 Cold Cranking Amps @ -18°C (0°F)
Alternator	40 amp, regulated

OUC2005.00001CC-19-12SEP13

Fuel System

Fuel Filter	Replaceable Element
Fuel	Diesel

OUC2005.00001CD-19-12SEP13

Steering and Brakes

Steering	Rack and Pinion
Brakes	Hydraulically Operated Four Wheel Disk

JG81906.0000761-19-01APR13

Specifications

Tires

Turf Trac RS and AT489

Front	24 x 9.5-10
Rear	24 x 12.0-10

ALL Trail II

Front	24 x 9.5-10
Rear	24 x 10.5-10

Inflation Pressure

Front	97 kPa (14 psi)
Rear	97 kPa (14 psi)

JG81906.0000762-19-01APR13

Capacities

Fuel Tank	20.0 L (5.25 gal)
Crankcase (with filter)	2.2 L (2.3 qt)
4WD Front Differential	150 ML (5 oz)
Transaxle	4.5 L (4.8 qt)
Cooling System (including recovery tank)	5.0 L (5.2 qt)

MX10673.000005B-19-03AUG17

Dimensions

Width (overall)	1.52 m (60.0 in.)
Length (with bumper)	2.87 m (113.0 in.)
Height (with OPS)	1.87 m (73.5 in.)
Ground Clearance	15.2 cm (6.0 in.)

JG81906.0000764-19-01APR13

Weights

Weight (Empty vehicle with full fluids)	778 kg (1715 lb)
Gross Vehicle Weight Rating (GVWR)	1383 kg (3050 lb)
Payload Capacity	635 kg (1400 lb)
Cargo Box Capacity (Not to exceed GVW)	454 kg (1000 lb)
Towing Capacity (Not to exceed GVW)	590 kg (1300 lb)
Maximum Cart Tongue Weight	59 kg (130 lb)
Maximum Front Axle Load	450 kg (992 lb)
Maximum Rear Axle Load (Carlisle brand tires)	935 kg (2061 lb)
Maximum Rear Axle Load (Michelin brand tires)	900 kg (1984 lb)

MX10673.000005F-19-07AUG17

Specifications

Recommended Lubricants

Engine Oil	John Deere PLUS-50™
.....	John Deere Torq-Gard Supreme™
Grease	John Deere Multi-Purpose SD Polyurea Grease
.....	John Deere Multi-Purpose HD Lithium Complex Grease
Transmission Oil (Transaxle)	John Deere HY-GARD™ (JDM J20C)
Transmission Oil (4WD Front Differential)	John Deere Low Viscosity HY-GARD™ (JDM J20D)

(Specifications and design subject to change without notice.)

OUO2005 00001D0-19-12SEP13

Specifications

John Deere Quality Statement

John Deere Quality

John Deere equipment is more than just a purchase, it's an investment in quality. That quality goes beyond our equipment to your John Deere dealer's parts and service support. This support is needed to keep you a satisfied customer.

That's why John Deere has initiated a process to handle your questions or problems, should they arise. The following three steps will help guide you through the process.

Step 1

Refer to your operator's manual

- A. It has many illustrations and detailed information on the safe and proper operation of your equipment.
- B. It gives troubleshooting procedures, and specification information.
- C. It gives ordering information for parts catalogs, service and technical manuals
- D. If your questions are not answered in the operator's manual, then go to Step 2.

Step 2

Contact your dealer

- A. Your John Deere dealer has the responsibility, authority, and ability to answer questions, resolve problems, and fulfill your parts and service needs.
- B. First, discuss your questions or problems with your dealer's trained parts and service staff.
- C. If the parts and service people are unable to resolve your problem, see the dealership manager or owner.
- D. If your questions or problems are not resolved by the dealer, then go to Step 3.

Step 3

Contact John Deere

- A. Your John Deere dealer is the most efficient source in addressing any concern, but if you are not able to resolve your problem after checking your operator's manual and contacting your dealer, contact John Deere for assistance.
- B. For prompt, effective service, please have the following ready before you call:
 - The name of the dealer with whom you've been working.
 - Your equipment model number.
 - Number of hours on machine (if applicable).
 - Your serial number which you recorded on the inside front cover of this manual.
 - If the problem is with an attachment, your attachment identification number.

C. Then call 1-800-537-8233 (United States and Canada) and our advisor will work with your dealer to investigate your concern. If you are outside the United States and Canada, visit the following website:

http://www.deere.com/globalhome/deerecom/global_home.page?CC=true

Select your country and then click on the Contact Us link.

SP66632 00043A7-19-10MAY17

Service Records

Record Service Dates

Oil Change	Oil Filter Change	Lubricate Machine	Air Cleaner Element Check/Clean	Fuel Filter Change	Coolant Change

JG81906,000076C-19-05APR13

Index

A	
Accessory Outlet, Using	34
Air Intake, Checking Hoses and Clamps	54
Air Restriction Indicator, Checking	52
Alarm, Backup	47
B	
Battery and Terminals, Cleaning	69
Battery, Checking the	69
Battery, Removing and Installing	69
Battery, service safely	69
Battery, Using Booster	70
Belt, Checking Drive	64
Belt, Replacing Drive	64
Belt, Servicing the Alternator	71
Brake Fluid, Checking	66
Brakes	
Brake lines, checking	67
Brake pads, checking	66
Brakes, Troubleshooting	83
C	
Cab Classification	45
Cargo Box, Emptying	41
Cargo Box, Loading	41
Cargo Box, Using	37
Chains, Tire	43
Cleaning, Machine	25
Clutch Buttons, Checking Secondary Driven	64
Clutch, Primary Drive, Cleaning	64
Controls, Operator	27
Coolant Level, Checking	56
Coolant system, servicing	57
Coolant, Engine	59
Cooling System, Service Safely	57
D	
Diesel Fuel, Using	75
Doors, Using	28
Drive Line, Lubricating	50
Dust Unloading Valve, Cleaning	52
E	
Electrical, Troubleshooting	83
Electronic display, use properly	18
Element, Servicing Air Cleaner	53
Emergency Stopping	36
Engine Compartment, Cleaning	56
Engine, Starting the	35
Engine, Stopping	35
Engine, Troubleshooting	82
Exit lighting, operation	34
F	
Filter, Changing Engine Oil	51
Fluid, Brake	66
Four Wheel Drive, Using	37
Front Differential Oil, 4WD	62
Fuel Safety	18
Fuel Storage	84
Fuel System, Bleeding	55
Fuel Tank, Filling	75
Fuse Filaments, Checking	79
Fuses, Replacing	72
Fuses, Replacing (Homologation)	73
G	
Grease	50
Grille, Cleaning	56
H	
Hand Holds, Using	29
Hazard Lights, Using	34
Headlight, adjusting	70
Headlights, Using	31
Heater, Using	48
Hitch, Front Receiver	48
Hood, Opening and Closing	78
I	
Instrument cluster controller buttons, using	32
Instrument cluster controller, using	31
K	
Key Switch, Using	31
L	
Labels, safety no-text	7
Lifting Machine	77
Lights, Optional, Replacing Bulbs	46
Load Capacity	40
Loads, Towing	41
M	
Metal Surfaces, Repairing and Cleaning	80
O	
Oil, Changing Transaxle	63
Oil, Checking Engine	51
Oil, Engine	51
Oil, Transaxle	62
Operating Checklist, Daily	28
P	
Park Brake, Adjusting	68
Park Brake, Using	31
Parking Safely	12, 20
Plastic And Painted Surfaces, Avoid Damage	
To	28

Index

Plastic Surfaces, Cleaning 80

Q

Quick Clamps, Using 45

R

Radiator cooling fins, cleaning 56

Radiator hoses and clamps, checking 60

Rear Screen, OPS 48

Record service dates 91

Replacement parts 3

S

Safety labels, no-text 7

Safety Start System, Testing 30

Safety Systems, Testing 30

Safety, Operating 11

Safety, Tire 17

Seat belt, inspecting 79

Seat belt, using 29

Seats

 Operator, adjust 29

Seats

 Removing and installing 76

Sediment Bowl, Servicing 54

Service intervals 49

Service Safety 16

Spark Arrestor, Checking 60

Spark Arrestor, Using 12

Storage Tray, Using 34

Storage, Preparing Machine for 84

Storing Safety 84

T

Tires, Inflation 42

Traction Assist, Using 36

Transaxle, Checking Oil 63

Transporting Utility Vehicle 43

Travel Controls, Using 36

Troubleshooting Chart 82

Turn Signal Switch, Using 34

W

Wheel Assembly, Removing and Installing 76

Windshield, maintenance 80

Notes

Notes

Notes
